

# CHAPTER 11

---

## PROBLEMS IN THE APPLICATION OF BROADBAND HEARING AID EARPHONES

Mead C. Killion

---

### CONTENTS

A REVIEW OF SOME TRADITIONAL PROBLEM AREAS .....	220
Noise in the Hearing Aid .....	220
Distortion .....	220
Limitations in Frequency Response .....	225
Poor Transient Response .....	229
Peaks in the Frequency Response .....	231
A LOOK AT THE COUPLING PROBLEM .....	235
The Problem with Tubing Resonances .....	235
Carlson's Twin-Tube Solution .....	241
Stepped-Diameter Tubing .....	241
Exponential Couplers (Horns) .....	247
A Delivery Problem .....	248
Another Look at the Battery Drain Trade-Off .....	253
Amplifier Source Impedance .....	254
SUMMARY AND CONCLUSIONS .....	257
APPENDIX: A LISTENING TEST DEMONSTRATION .....	259
PROCEDURE .....	259
THE SYSTEMS COMPARED .....	259
RESULTS .....	261
ACKNOWLEDGMENTS .....	262
REFERENCES .....	262

This chapter was at least partly prompted by an often-heard statement that starts with the phrase "If only suitable hearing aid transducers were available, . . ." The main thrust of this chapter is a demonstration that suitable transducers *are* available. With the exception of hearing aids intended for the severely or profoundly deaf—where extraordinarily high output sound pressures are sometimes required—both transducer and amplifier technolo-

---

An informal listening test demonstration preceded the formal presentation of this paper. A description of that listening test, and a summary of the hearing aid fidelity ratings obtained from 122 (audience) participants, is given in the chapter appendix.

gies have reached the point where the hearing aid designer can produce almost anything one might ask for in a hearing aid, including high fidelity.

## A REVIEW OF SOME TRADITIONAL PROBLEM AREAS

### Noise in the Hearing Aid

There are two aspects of the noise problem: one involves amplification of noise generated within the hearing aid, and the other involves amplification of external background noise. In a modern hearing aid, the internally generated noise is very low. The primary noise component is caused by the microphone, and modern subminiature microphones have A-weighted noise levels some 5 dB lower than that found in a quiet concert hall and some 15–20 dB lower than that found in a typical residence. The aided threshold determined by the microphone noise level can be within a few dB of normal threshold (Killion, 1976a).

The second aspect of the noise problem is the subjective magnification of background noises. When a hearing aid has (rightly or wrongly) an intentionally restricted bandwidth combined with high frequency emphasis, the initial user reaction is sometimes that of “trying to understand speech in a background of noise.” This problem usually disappears after the hearing aid is worn for awhile. There appears to be less adjustment required with broadband hearing aids having smooth frequency response, except when the volume control is turned up too high.

### Distortion

Distortion in hearing aids is basically a problem of amplifier design. Surprisingly high peak pressures are frequently presented to the input of the hearing aid; a spoon dropped onto a plate can produce a 110- to 115-dB sound pressure level (SPL) peak. Even commonly encountered speech can produce high SPLs. My daughter’s enthusiastic “Hi Dad” at 2½ feet is good for a 114-dB SPL peak at a head-worn hearing aid inlet port. Although commonly available microphones are linear up to 114 dB SPL, that sort of microphone input produces a peak microphone output voltage of 0.15 V. With only a 1.5-V supply available, therefore, anything over 20 dB of *electrical* gain (corresponding to at most a few dB of acoustic gain) will cause amplifier overload unless some sort of low distortion compression limiting is included in the amplifier design.

**Earphone Distortion** The earphone itself is seldom the limitation in anything except high-powered class B hearing aid designs. With the high frequency emphasis in most hearing aids, distortion is most likely to occur at high frequencies. Figure 1 shows the maximum undistorted output capa-

bility of the Knowles Electronics BP-series of earphones (Carlson, Moscardo, and Diblick, 1976) when used with a well-damped conventional earmold in a Zwislocki-type ear simulator (Zwislocki, 1971). Here we see the direct trade-off available between the maximum undistorted high frequency output and the battery drain of the hearing aid, assuming a constant low frequency output is maintained. The typical earphone response seen in a manufacturer's data sheet is often obtained with the earphone output fed through an undamped tubing to a 2-cc coupler, and thus will have more peaks and valleys than the curves shown here, but is otherwise similar to the broken curve in Figure 1.

The broken curve was obtained under maximum current modulation (MCM) conditions, where a DC current equal to the nominal bias rating of the earphone was applied, and an AC current having a peak value equal to the DC bias current was superimposed. (Thus the net current in the earphone swings from zero to twice the rated bias current and back on each cycle of the AC wave form.) From the earphone manufacturer's viewpoint, such an MCM response curve has the advantage of a single curve applying to all earphones in a model series, regardless of the number of turns wound on the internal coil; i.e., regardless of the electrical impedance of the receiver. From the hearing aid designer's standpoint, however, a family of solid-line curves like those shown in Figure 1 contains more useful information because it tells him the earphone impedance he should order and the battery drain of the amplifier that will be required to produce a given high frequency undistorted sound pressure level.

The family of curves shown in Figure 1 is not unique (a different family is obtained each time the earphone-to-eardrum coupling system is changed), but serves to illustrate three points:

1. The battery drain of the hearing aid is likely to be determined by the high frequency output that is required. (We assume that the low frequency output is to be maintained constant.)
2. If the high frequency sound pressure levels seen on a typical hearing aid earphone data sheet are to be obtained, a fairly low nominal earphone impedance must be selected.
3. The undistorted output capability of the earphone itself substantially exceeds the undistorted output available from a typical single-ended class A hearing aid amplifier.

*The Distortion Level in Ears* Another comparison that can be made is that between the distortion produced by nonlinearity in the hearing aid earphone and the apparent distortion produced by nonlinearity in the normal ear itself. (We assume that distortion in the impaired ear is at least as great.) One such comparison is shown in Figure 2, which represents an

SUPPLY: 1.5V  
 AMPLIFIER: CLASS A, SINGLE ENDED  
 BIAS CURRENT: NOMINAL RATED BIAS FOR EACH EARPHONE IMPEDANCE  
 EARMOLD: 40 MM OF 1.9 MM Ø (#13) TUBING WITH TWO 1500 OHM DAMPERS

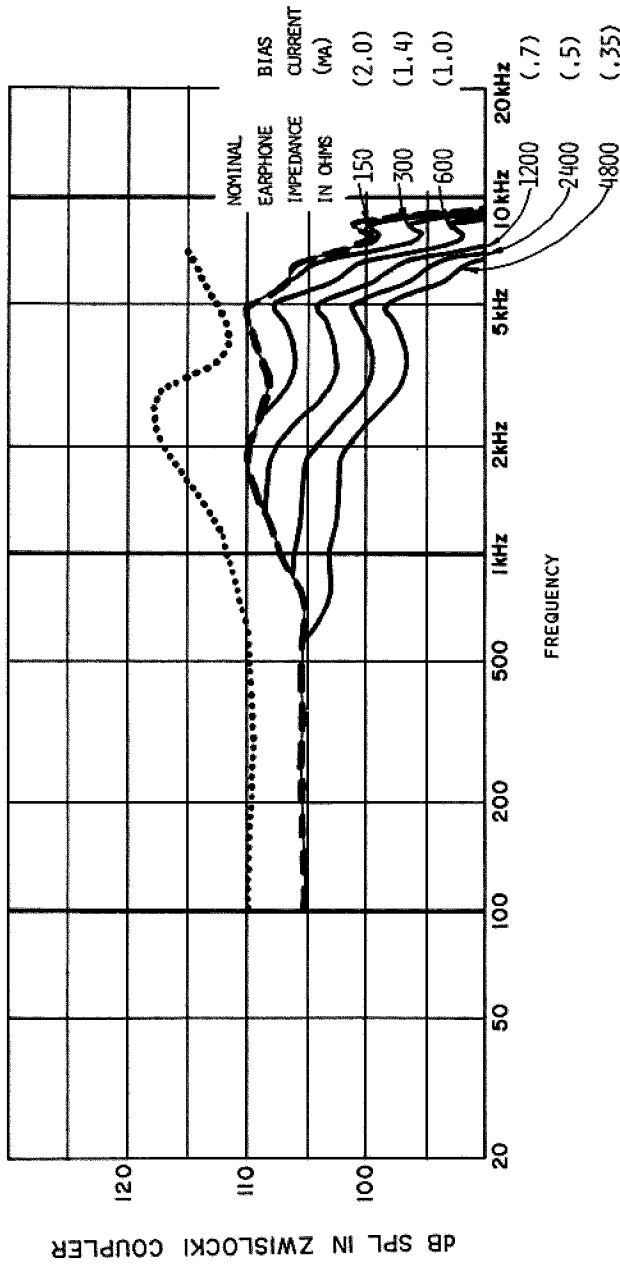

Figure 1. Maximum undistorted output of Knowles BP-series earphone with well-damped conventional earmold, limited by earphone overload (dotted line), amplifier current clipping (broken line), and amplifier voltage clipping (solid line).

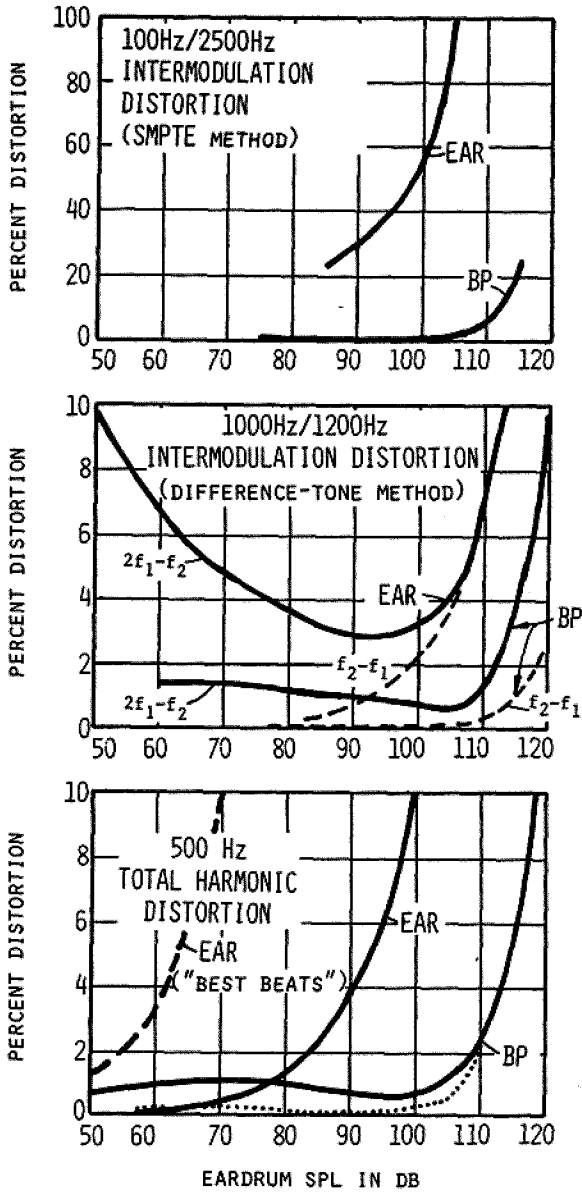

Figure 2. Apparent distortion levels in normal ears and in the BP-series broadband hearing aid earphones.

attempt to pull together some two dozen studies on aural distortion and combination tones.

The top graph in Figure 2 is based on some recent data of Zwicker (1976), who was looking for the psychoacoustic equivalent of the period histogram typically found in single-unit neural firings recorded from nerve VIII. Zwicker found that a brief 2500-Hz tone pip was made completely inaudible when added to an intense 100-Hz tone on one-half of the 100-Hz wave form, but was quite audible on the other half. Such a result corresponds to 100% intermodulation distortion as would be measured on earphones using the so-called SMPTE (low-tone, high-tone) method (Moir, 1958).

The middle graph shows an average of the results of several studies on the level of the two most prominent combination tones: the cubic difference tone at  $2f_1 - f_2$  and the simple difference tone at the frequency  $f_2 - f_1$ . These correspond to the intermodulation distortion products as would be measured on earphones using the so-called CCIF (difference-tone) method (Moir, 1958).

A good estimate of the harmonic distortion levels in the ear is the hardest to come by. For years after it was first used by Wegel and Lane (1924), the "best beats" method was the commonly accepted method for estimating the level of aural harmonics. The broken curve in the bottom graph is derived from several studies in which that method was used. The problem with that method, as pointed out 40 years ago by Trimmer and Firestone (1937), is that no one ever *hears* these harmonic distortion products. A more conservative estimate is shown by the solid curve labeled EAR in the bottom graph, based on a "phase" method used by Clack, Erdreich, and Knighton (1972) and deBoer and Bouwmeester (1975).

The important conclusion that can be drawn from Figure 2 is that the distortion produced by available broadband hearing aid earphones is well below that generated by the nonlinearities in the ear. It would take some 20 dB of pure conductive hearing loss before the earphone distortion became comparable to that of the ear.

The (BP-series) earphone distortion curves shown in Figure 2 are generally "worst-case" figures, since these curves were obtained by using a 6R12 earmold (Knowles and Killion, 1978), whose enhanced high frequency response tends to emphasize the higher frequency distortion products. A further reduction in earphone distortion can be obtained by the use of a low impedance amplifier (as shown by the dotted curve in the bottom graph in Figure 2), rather than the high impedance amplifier used to obtain the solid curve.

### Limitations in Frequency Response

**Microphones** Until roughly a decade ago, the frequency response available in a practical head-worn hearing aid was limited by the magnetic microphones available at the time. These had been designed intentionally to produce a rising response with a bandpass filter characteristic. Since that time, a wide variety of microphone types, and microphone frequency responses, have become available. Figure 3 shows just a few of the frequency responses that are available today in subminiature microphones. The curves in Figure 3 were obtained on the microphone by itself in each case. When the effect of the various coupling tubes commonly used with these microphones is included, a much wider variety of responses can be obtained.

Although both the ceramic microphones and the electret-condenser microphones are available in flat frequency-response versions, they are most often provided with a peak in response in the neighborhood of the unoccluded external ear resonance. This frequency-response tailoring helps compensate for the loss of external ear resonance when the earmold is inserted; it began in 1968, when the subminiature broadband ceramic microphones were first introduced (Killion and Carlson, 1970).

**Earphones** A similar variety of frequency responses is available from subminiature hearing aid earphones. Figure 4 shows a small sampling of the response curves that are available. The original intent was to show the response of a variety of earphone types, mounted in a variety of hearing aid cases, driven from a variety of amplifier source impedances, and coupled to a variety of earmolds. We only got as far as the variety of earmolds. All curves were obtained with a single BP-1712 earphone mounted in an over-the-ear (OTE) hearing aid case (as shown in Figure 16), and driven from a high impedance source (0.01  $\mu$ F shunted the earphone terminals). The only changes made to obtain the curves shown in Figure 4 were in the earmold constructions. As is obvious from the extensive discussion of earmold venting by Lybarger (Chapter 10, this volume), it would have been possible to add another series of curves to Figure 4 by including a variety of earmold ventings. Only one vented earmold is shown in Figure 4: the near-extreme case of the "acoustic modifier" type of earmold.

It is apparent from the variety shown in Figure 4 that even defining the term *broadband earphone* can be difficult. The curves shown in Figure 5 represent the best comparison we have made to date between conventional and broadband earphones. These response curves were obtained with the earphones mounted in OTE hearing aid cases and coupled with 40 mm of #13 earmold tubing to a Zwislocki coupler. Two 1500- $\Omega$  dampers were placed in the earmold tubing to smooth the frequency response, one at the earhook and one 6 mm back from the tubing outlet. The only change

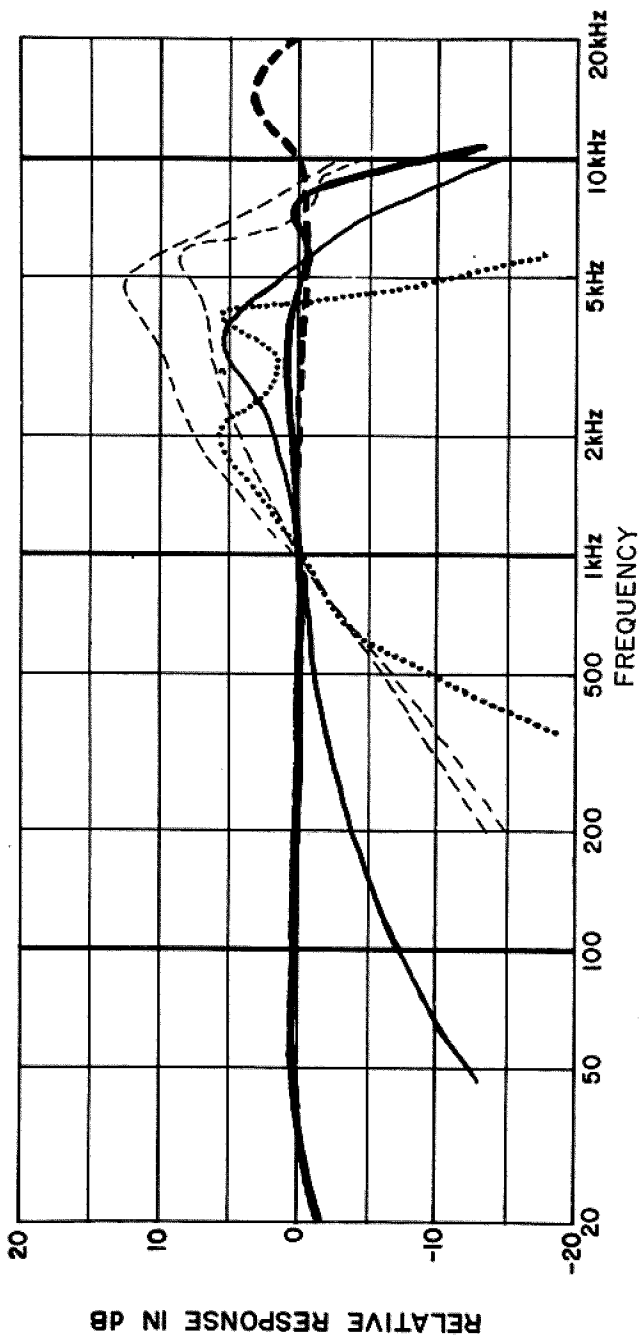

Figure 3. Some response curves available in 6 mm<sup>3</sup> (0.01 cubic inches) or smaller microphones.



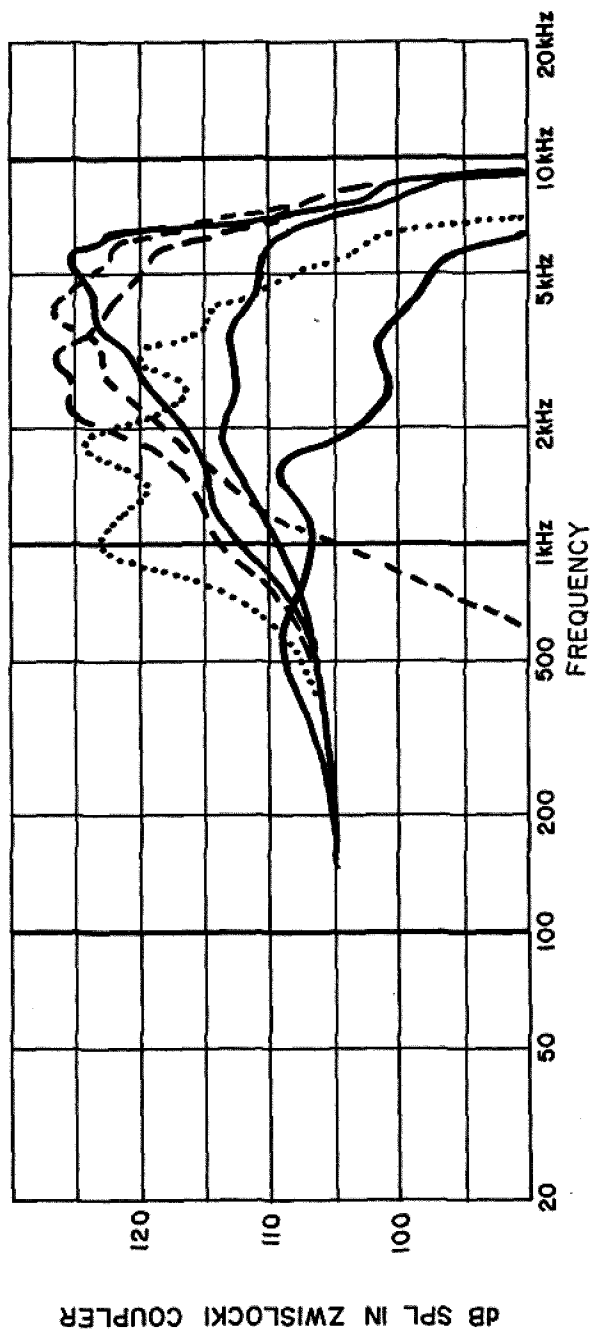

Figure 4. Wide variety of response curves obtained (with a single earphone) by changing the earmold construction.

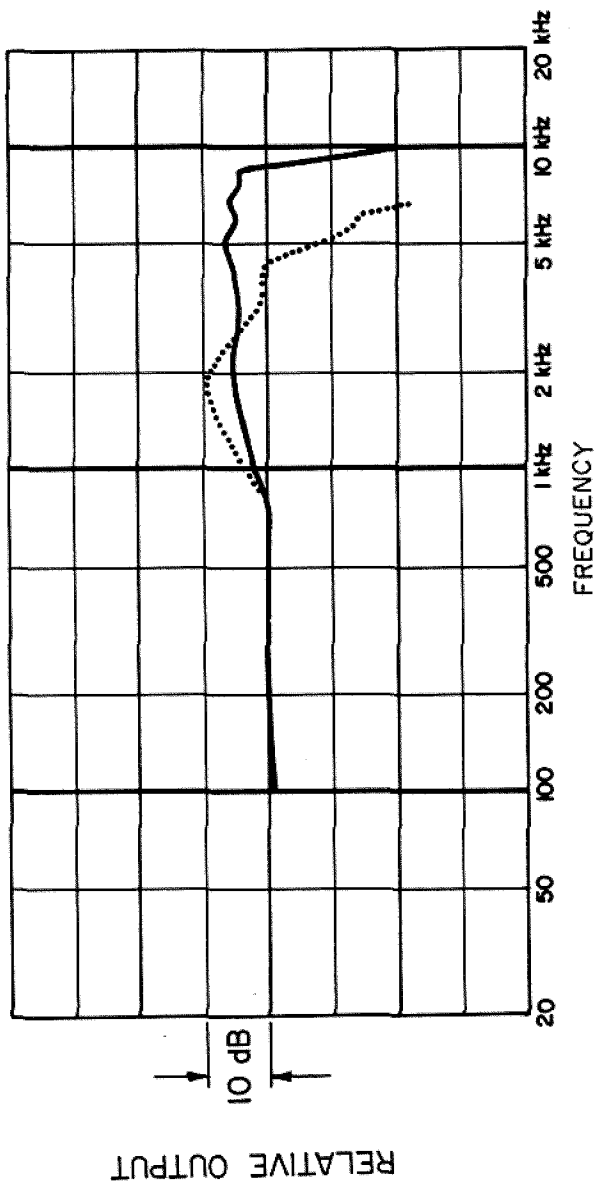

Figure 5. Comparison between broadband BP-series earphone (solid line) and conventional BK-series (dotted line) earphone with one well-damped earmold coupling.

between the two curves shown in Figure 5 was a change in the shunt capacitance used to obtain a maximum increase in high frequency output with each earphone.

Before leaving the question of frequency response, one comment is in order: the frequency responses in Figures 1, 3, and 4 have been plotted to the engineering standard scale of 30 dB/decade, instead of the hearing aid standard scale of 50 dB/decade. Figure 6 illustrates the visual effect of the different scales on one completed hearing aid frequency response. Transducers by themselves have traditionally been plotted on the engineering scale, and so most of the frequency response curves used in this chapter are plotted on the 30 dB/decade engineering scale.

However the curves are plotted, it is clear that almost unlimited combinations of frequency responses are available with present hearing aid transducers:

### Poor Transient Response

There are two common interpretations for the term *poor transient response*. One is the difference between the output and input wave forms viewed on an oscilloscope when a transient is applied to sound reproduction system. In general, this difference is an inevitable consequence of any frequency-response shaping in the system under test. By this definition, for example, the ear itself has a very poor transient response because of the resonances in the external ear.

To a reasonable first approximation, a hearing aid system can be represented as a minimum-phase network. Under those circumstances, the transient response can be predicted directly from the frequency response. The frequency-response tailoring of a particular hearing aid may or may not be useful, but its effect on "transient response" is inevitable (Mott, 1944). A comprehensive set of frequency-response curves and their corresponding transient-response wave forms was shown by Mott.

The other type of "poor transient response" generally involves an amplifier that exhibits a slow recovery from overload. As mentioned previously, instantaneous peak sound pressure levels of 110 to 115 dB at the hearing aid input are not uncommon. Such peaks can easily cause sufficient amplifier overload to upset the bias levels on the internal coupling capacitors, causing a high amplifier distortion condition lasting much longer than the transient itself (Ingelstam et al., 1971; Killion, Carlson, and Burkhard, 1970). This "blocking distortion" was more often a problem with older amplifier designs, and is much less of a problem now that the majority of hearing aids use some form of fast-acting compression-limiting or AGC system.

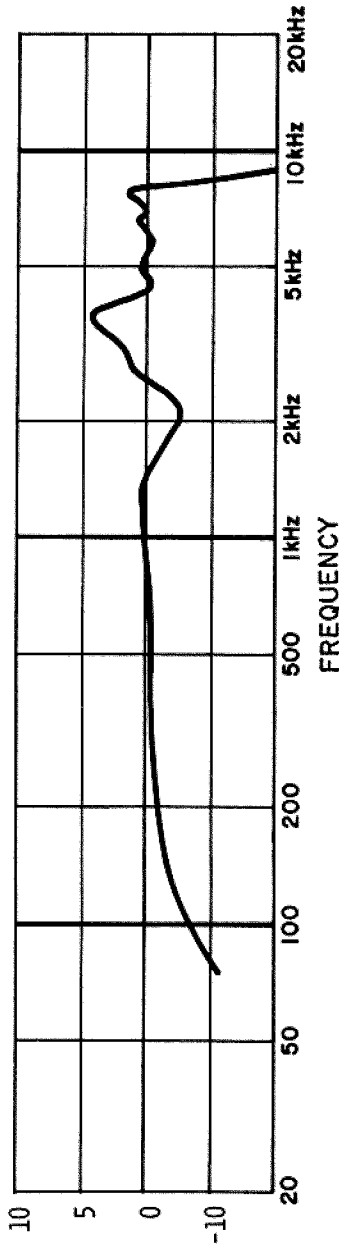
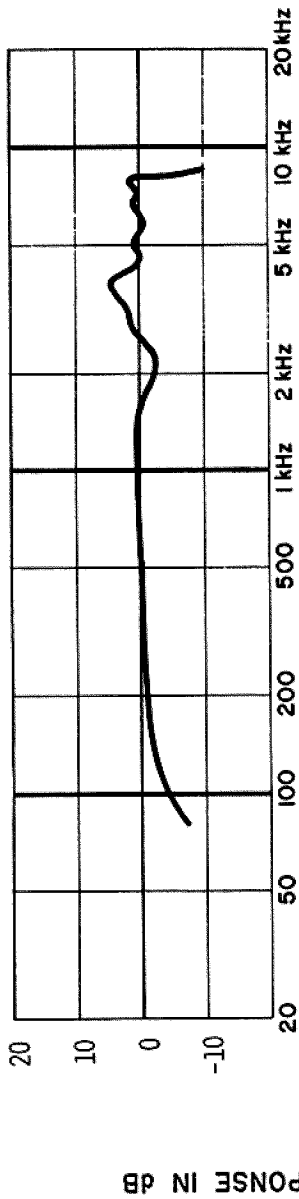

Figure 6. Calculated insertion gain (random incidence) of an OTE experimental hearing aid, plotted on two scales: 50 dB/decade hearing aid standard scale (upper graph), and 30 dB/decade engineering standard scale (lower graph).

### Peaks in the Frequency Response

Although many hearing aids are sold that produce peaks in the frequency response, it is not because of a lack of engineering solutions. Figure 7, for example, shows the smooth response obtained in a body-worn aid designed by Lybarger (1949).

The AR series of earphones that Knowles introduced in 1955 were the first earphones small enough to be mounted in a head-worn hearing aid and were specifically designed to be used with a long transmission line, i.e., with a plastic tube coupling the earphone output down to the tip of the earmold. As part of the original design, removable damping elements were provided. These did an excellent job of smoothing the tubing resonances, as shown in Figure 8. At that time, the earphone was large enough that its acoustic impedance was quite low, and thus the tubing resonances could be well damped by the use of an acoustic resistance placed directly at the earphone outlet. These dampers were made available to dispensers through the manufacturer who supplied the hearing aids, but most hearing aids were sold without dampers. A typical reaction was, "Sounds louder without the damper," so the damper was not used.

It would be easy to show a series of frequency responses of hearing aids designed over the years with smooth frequency responses obtained by the proper use of damping; nonetheless, these hearing aids have remained a small factor in the marketplace.

There appear to be several reasons for this. First, the peaks caused by tubing resonances produce a greater hearing aid output for the same battery

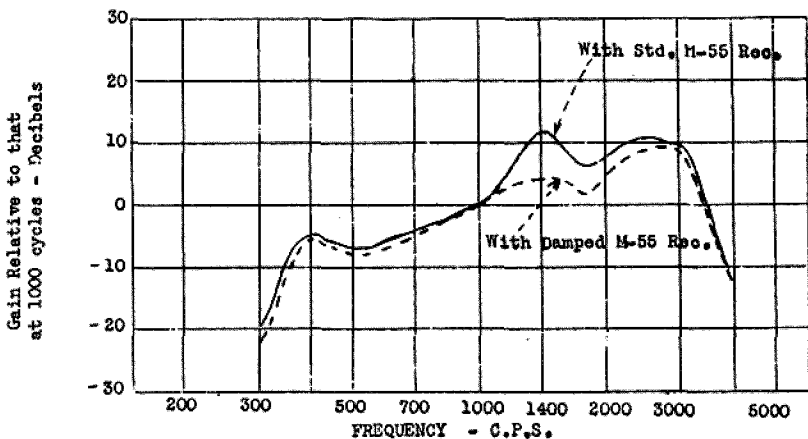

Figure 7. Well-damped (body-worn) hearing aid response designed in the 1940s. (Reprinted with permission from Lybarger, 1949, Damping elements for M-55 receivers, *Radioear Voice*, Jan.-Feb., pp. T1-T4.)

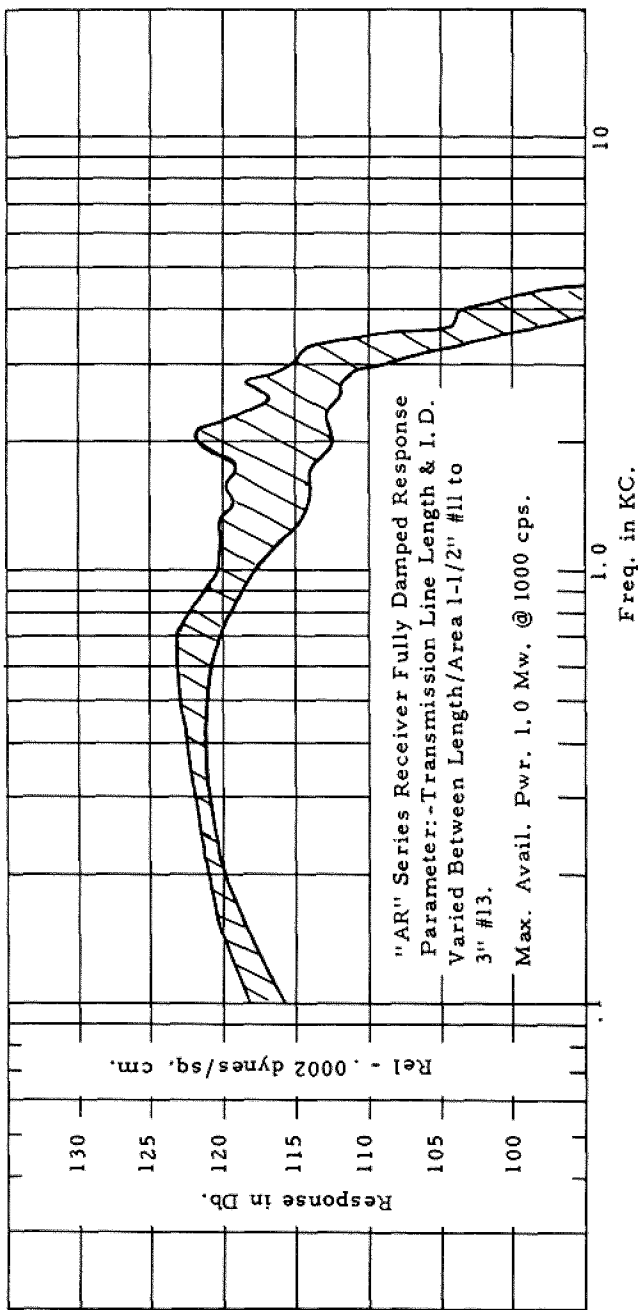

Figure 8. Well-damped (head-worn) hearing aid earphone response available in the 1950s. (Reprinted with permission from Knowles, 1955.)

drain. Producing a truly well-damped earphone-tubing system may lower the high frequency saturation sound pressure level (SSPL) output figure on the data sheet by some 6 dB. Restoring that saturation output will require typically two to four times the battery drain. The first head-worn aids were power limited because of available battery and amplifier technology, so the biggest obstacle to the sale of head-worn aids was their lack of loudness. Removing the damping made the head-worn aids sound much louder, and dealers found that "loudness sells."

Another reason was that the perturbation in the binaural phase-frequency relationships introduced by undamped tubing resonances turned out to be much less of a problem than originally anticipated. Experiments conducted by Knowles in the 1950s showed that only a few days of reeducation were generally required before normal binaural localization was restored for the head-worn hearing aid user.

Probably the most important reason that well-damped hearing aid responses have not dominated the marketplace to date is that even completely undamped earmold-tubing resonances do not sound as bad as might be expected, especially with the stepped diameter coupling used in most modern hearing aids. Figure 9 shows a comparison between two different earphone earmold responses used with an experimental OTE hearing aid to produce some of the prerecorded comparisons used in the listening test demonstration (see appendix). As might be expected, the smooth response obtained with the well-damped earmold produced significantly higher average fidelity ratings (80%) than the peaked response obtained with the undamped earmold (63%). The relatively low fidelity rating obtained with the undamped earmold, however, exceeded the even lower ratings (56%) obtained for a (probably better-than-average) speech audiometer using the TDH-39/MX-41R headphones—a system that has often been characterized as "high fidelity" in the literature.

The results of the informal listening test conducted during the original presentation of this paper are similar to results obtained in more formal listening test evaluations using trained listeners. The loss of bass response because of the well-known cushion leak with the MX-41AR ear cushion appears to be more objectional to most listeners than the peaks introduced by the undamped earmold tubing. Indeed, the insertion gain frequency response of the experimental hearing aid with the undamped earmold (curve 4 in Figure 31) is not much different from the real-ear response of common airline stereo systems, when both are measured with  $\frac{1}{3}$ -octave bands of noise.

Nonetheless, there are several reasons to suspect that well-damped hearing aid responses will be more common in the future. Most of the listening test participants had normal hearing. Strong peaks in the fre-

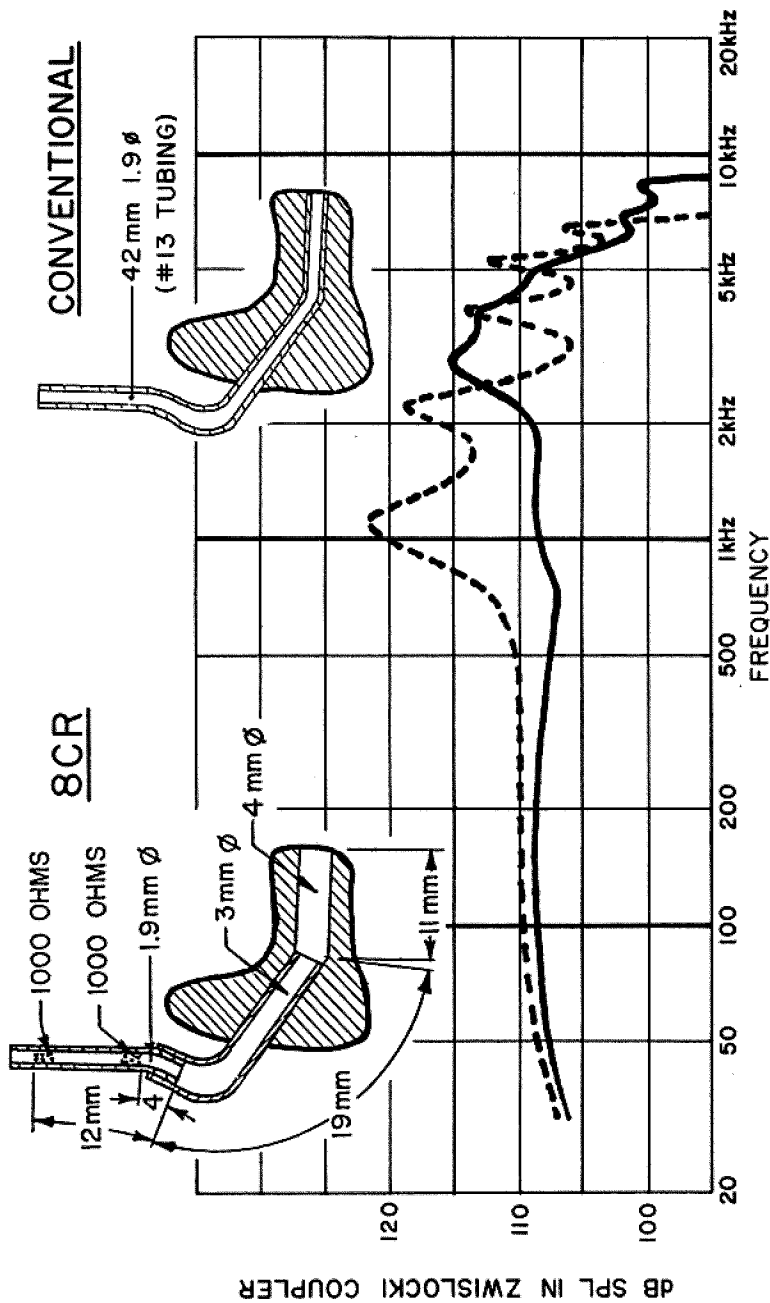

Figure 9. Comparison between 8CR (solid line) and conventional (broken line) earmolds used with broadband earphone. Note: BP-1712 earphone is mounted in OTE hearing aid case as shown in Figure 16, and driven from low impedance amplifier (0.7 mA DC bias, 0.56 VAC behind 330  $\Omega$  source impedance).



quency response are likely to be much more troublesome to someone with a severely limited dynamic range, because such peaks limit the maximum useful gain a user can employ without experiencing occasional discomfort when an intense vowel formant peak coincides with a peak in the hearing aid response. Moreover, peaks in the transmission characteristic tend to reduce the maximum usable gain before "whistling" because of acoustic feedback (or before changes in the effective frequency response occur as the whistling condition is approached; Lybarger, 1966; Cox and Studebaker, Chapter 9, this volume).

Last, there appears to be an increasing demand for higher quality sound reproduction in hearing aids. This demand seems likely to accelerate as the increasing availability of high fidelity hearing aids makes hearing aid usage more attractive to those for whom hearing aid usage is not a necessity, but simply makes hearing easier (Killion and Carlson, 1970, 1974). Such users generally do not require high sound pressure levels, so that the trade-off between battery drain and SSPL output of the hearing aid may be of little concern.

Fortunately, the usual trade-off between response smoothness and battery drain can be at least partially circumvented by the use of stepped-bore earmolds, as discussed in the next section.

## **A LOOK AT THE COUPLING PROBLEM**

### **The Problem with Tubing Resonances**

As smaller and smaller hearing aid earphones were designed, their acoustic output impedance inevitably went higher and higher. The broadband earphone discussed in this chapter, which was the smallest earphone commercially available when this chapter was written, has an acoustic source impedance that is almost 100 times greater than the acoustic impedance of the load represented by the ear canal and eardrum impedance. Figure 10 shows the well-known tubing resonance peaks that occur when such a high impedance source is connected to a low impedance load through a section of tubing. The curve in this figure was computer generated under the assumption that the earphone itself had a flat frequency response extending well beyond 40 kHz.

The advent of the digital computer made the routine calculation of the frequency response of a transducer tubing system practical. Before then, a typical transducer manufacturer would construct an electrical analog (using physical components) corresponding to each microphone and earphone series, and perhaps a lumped-element approximation to the transmission line formed by the tubing used to couple the earphone to the ear. (A

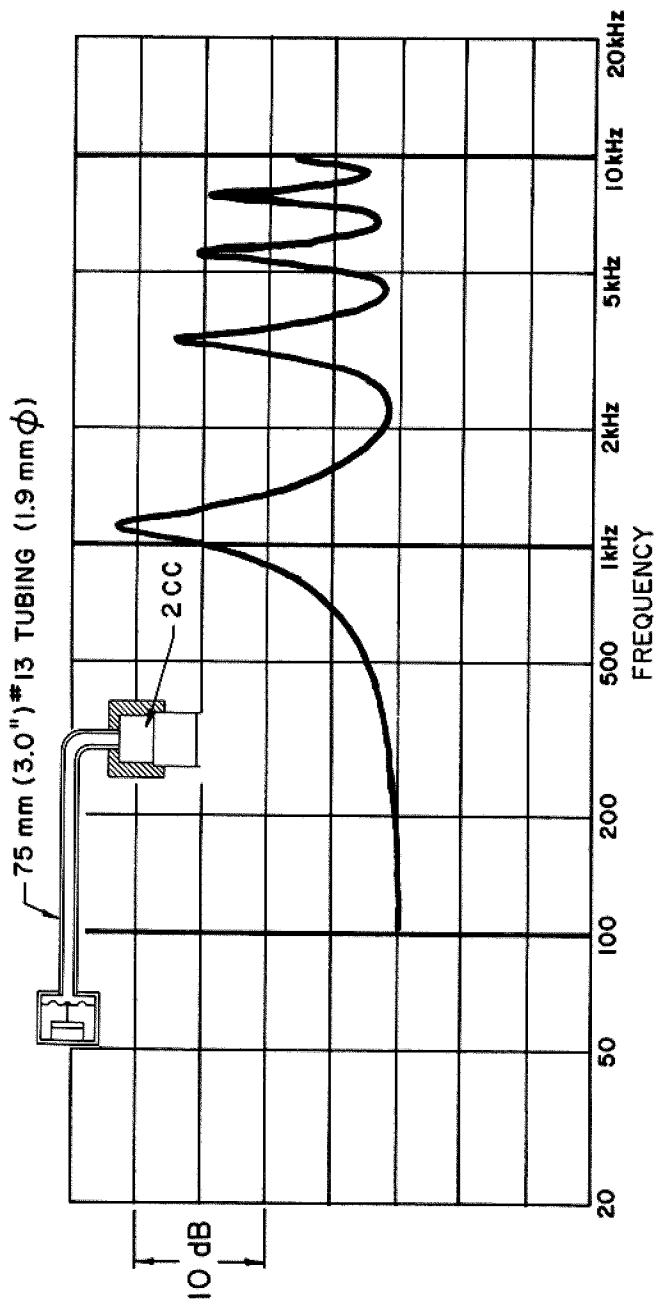

Figure 10. Calculated tubing resonances for 75 mm of tubing used with ultra-high frequency earphone.

10-section lumped approximation to 95 mm of 1.9 mm in diameter tubing was used at the writer's firm (I.R.P.I.) back in the late 1950s, for example.)

As discussed by White et al. (Chapter 12, this volume), the use of electrical analogs in transducer design has been routine since the Harrison (1929) and Norton (1928) disclosures. Similarly, the use of transmission line equations in treating acoustic coupling tubes has been routine since Mason's papers (1927, 1930) and Stewart's disclosure (1928), in which the continuous and equivalent-T lumped-element representations were discussed. The curve shown in Figure 10 was calculated using Zuercher's (1977) approximations to the full Bessel function solution for acoustic tubes, approximations that allow highly accurate curve generation at a speed equal to that obtainable using automatic analog plotting equipment with physical analogs.

Figure 10 provides a graphic illustration of the problem of delivering a flat frequency response at the other end of a transmission line, a problem that was solved more than 80 years ago. The solution is to terminate the transmission line with a resistance equal to the characteristic impedance of the transmission line (Heaviside, 1899). In the case of an acoustic tube, the characteristic impedance is equal to 41 cgs  $\Omega$  ( $\rho c$  for air) divided by the cross-sectional area of the tubing. Approximately 1400  $\Omega$  is calculated for #13 (1.9-mm) tubing, for example.

Figure 11 illustrates the effect of terminating resistance on the behavior of an acoustic transmission line formed from the 1.9-mm tubing commonly used with hearing aids. Observe that too low a value of resistance provides insufficient damping of the response peaks, and that too high a value of resistance introduces a new set of peaks (this time at the even multiples of a quarter wavelength), whereas the proper resistance provides an almost perfectly flat frequency response.

Olney, Slaymaker, and Meeker (1945) applied this solution to eliminate the resonance peaks in a probe-tube style of noise-canceling microphone. The effectiveness of this approach when used with a broadband hearing aid earphone is shown in Figure 12. (Note that for consistency the last three figures have been 2-cc coupler curves.)

When applied to a hearing aid, the problem with the classical approach is that terminating the low impedance end of the transmission line with a resistance means placing a damping element at the tip of the earmold—a location where it is likely to become quickly clogged with earwax.

When both ends of the transmission line are connected to a low impedance (as in hearing aids using 1955 vintage large-volume earphones), the damping resistance can be placed at either end of the transmission line. With the high acoustic impedance of a modern broadband earphone, on the other hand, a damping resistor located at the receiver outlet will be safe from earwax but may have little effect on the tubing resonances. This is illustrated in Figure 13.

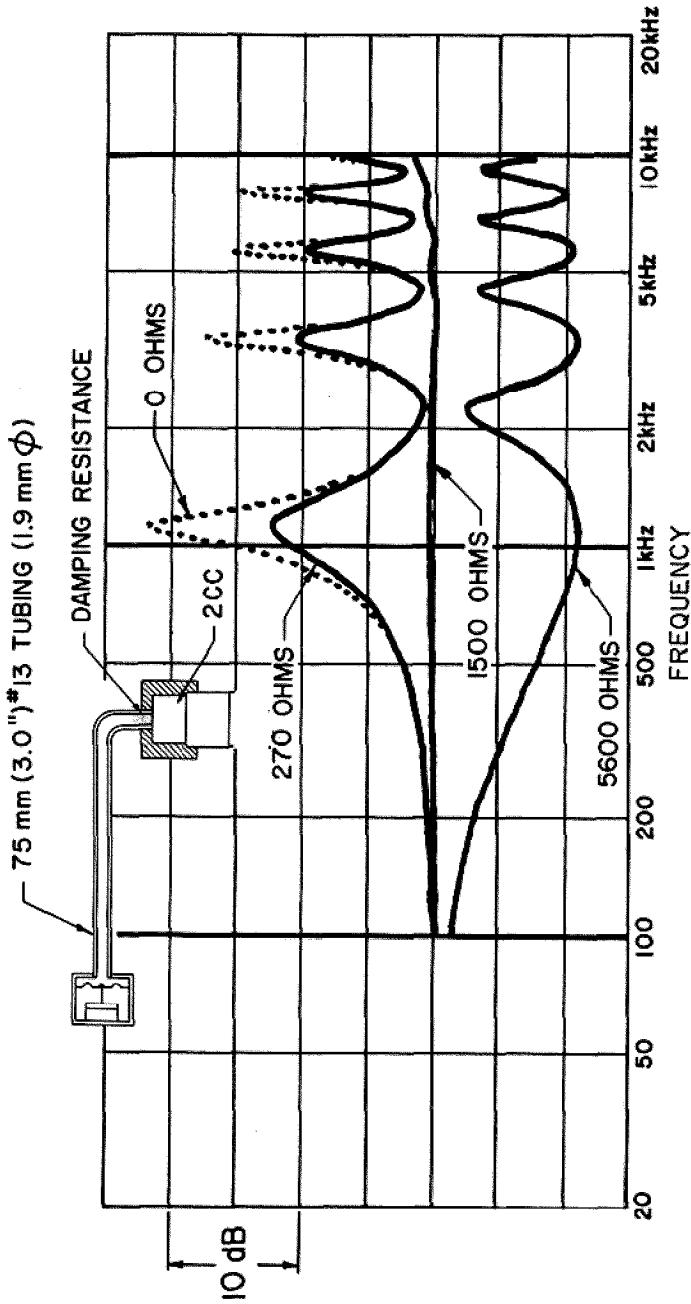

Figure 11. Calculated effect of damping applied to coupler end of 75 mm of tubing used with ultra-high frequency earphone.

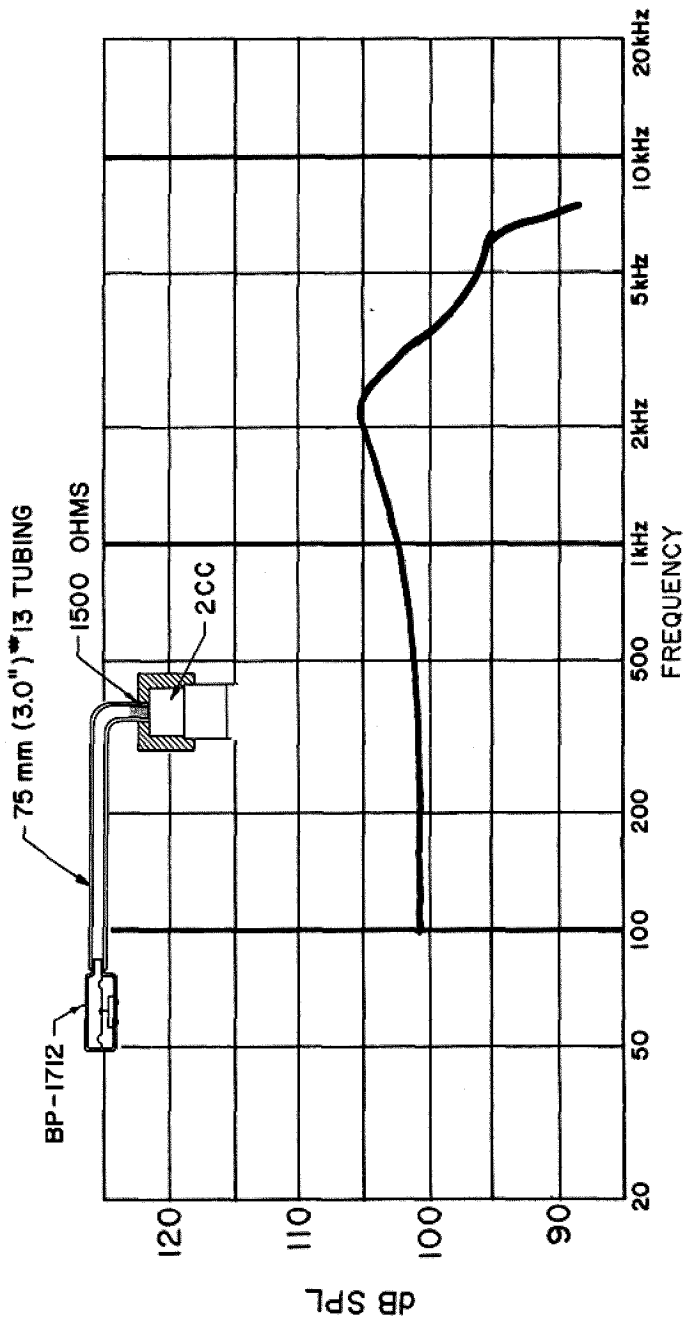

Figure 12. Measured effect of damping applied to coupler end of 75 mm of tubing used with broadband earphone.

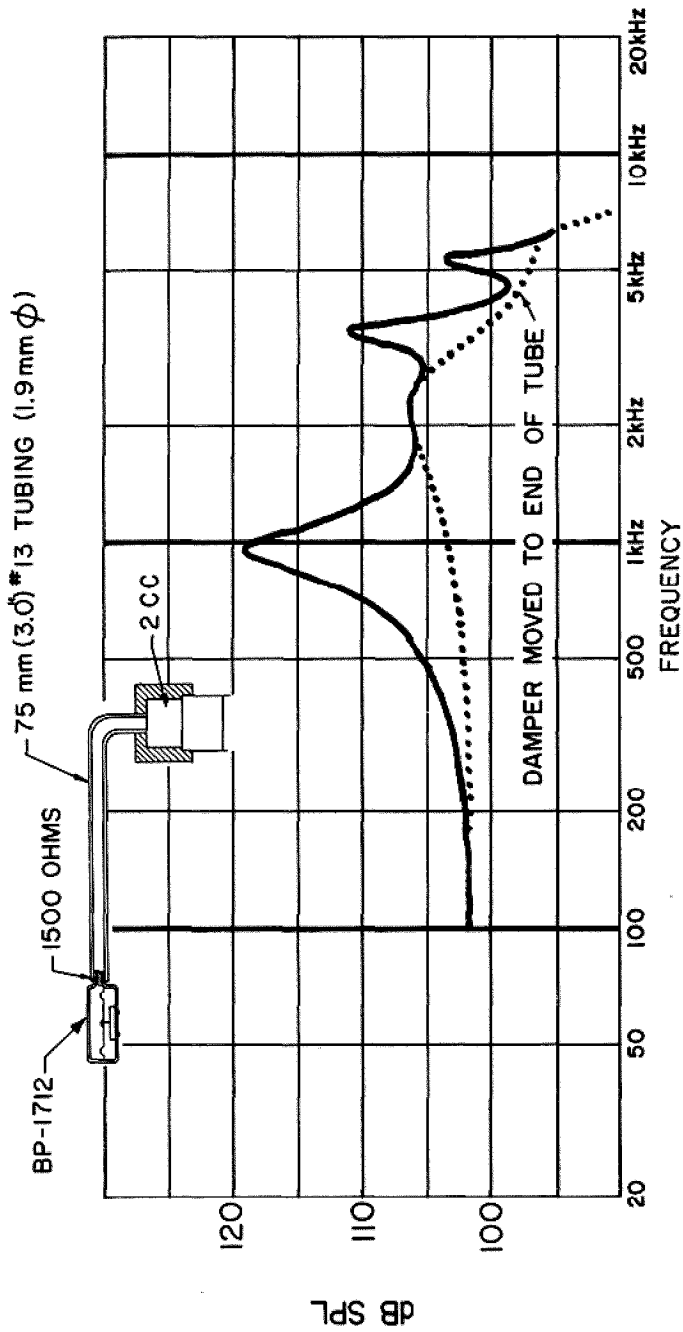

Figure 13. Comparison between effect of damping applied at earphone (solid line) and at coupler end (dotted line) of 75 mm of tubing used with broadband earphone.

### Carlson's Twin-Tube Solution

A novel and elegant method for damping all tubing resonances by use of dampers located near the earphone was described by Carlson (1974). One mechanical construction using this approach is shown in Figure 14. In essence, the Carlson twin-tube method uses an auxiliary tube that is blocked at the far end in order to provide an impedance conjugate to that of the main coupling tube, and thus in effect cancels the tubing resonances.

The effectiveness of the Carlson twin-tube approach is shown by the curves in Figure 15. Note that almost identical frequency response curves are obtained regardless of the length of the tube pair.

The Carlson solution is being used commercially by at least two hearing aid manufacturers; one uses a simplified lumped-element version. In the lumped-element version, a damped "Helmholtz resonator" is placed in shunt with the receiver output to absorb energy at an otherwise troublesome peak in the tubing transmission (Carlson, 1977).

### Stepped-Diameter Tubing

There is another approach to the impedance mismatch problem: to use some form of "horn coupling" between the earphone and the eardrum. As discovered years ago by hearing aid designers, a stepped-diameter coupling system not only improves the high frequency output of the hearing aid, but reduces the peak-to-valley ratio in the output frequency-response curve. Figure 16 shows a typical coupling system, with a small-in-diameter flexible tube connecting the earphone to an earhook, which has a slightly larger

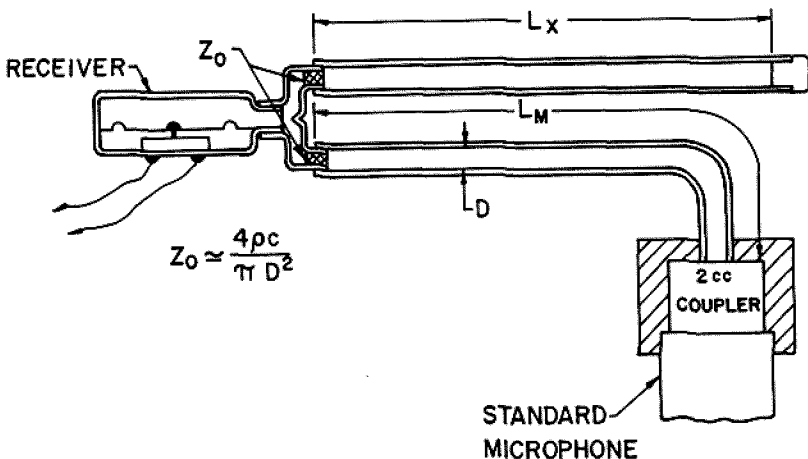

Figure 14. Example of Carlson twin-tube earphone coupling for smoothing the frequency response. (Reprinted with permission from Carlson, 1974.)

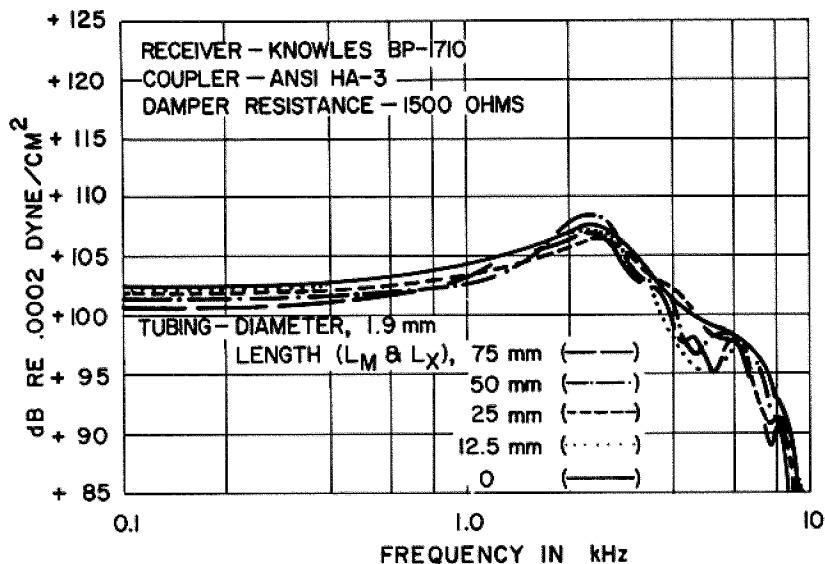

Figure 15. Measured effectiveness of Carlson twin-tube coupling used with various tubing lengths and a broadband earphone.

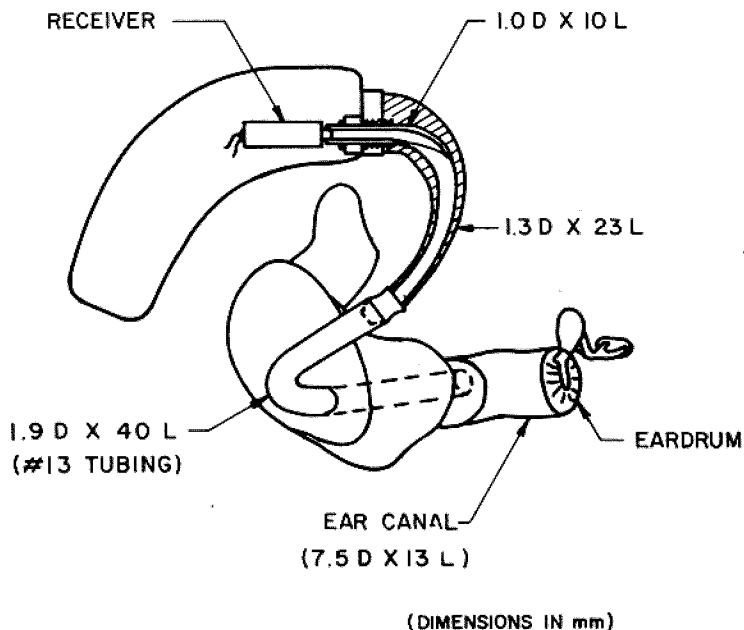

Figure 16. Typical earphone-to-eardrum coupling for OTE hearing aid.



diameter internal bore. The still larger-in-diameter earmold tubing then extends to the tip of the earmold.

The impedance transformation provided by this stepped-diameter coupling makes a damper placed at the earphone outlet much more effective in damping the tubing resonances, as illustrated in Figure 17. The combination of stepped-diameter coupling and a damping resistance placed at the receiver outlet or in the earhook has allowed hearing aid designers to produce hearing aids with smooth frequency responses for nearly two decades.

*Stepped-Diameter Earmold Construction* In the 1960s, Knowles suggested that the stepped-diameter approach to the transmission line problem be extended into the earmold itself. This approach was used in a commercial hearing aid design by Lybarger in 1970. Lybarger's earmold recommendation is shown in Figure 18. The increased high frequency response that could be obtained from such a stepped-diameter earmold in a hearing aid using a conventional earphone is shown in Figure 19.

Several years ago, I became interested in the potential improvement in the response smoothness and high frequency output that could be obtained by the use of stepped-diameter earmold bore in conjunction with broadband earphones. Initial experiments resulted in a demonstration that a relatively smooth response extending to 9 kHz was entirely practical using the proper earmold in conjunction with a broadband earphone (Killion and Carlson, 1973). Further experiments led to the development of the 6R10 earmold (Killion, 1976b).

The evolution of the frequency response of the 6R10 earmold is shown in Figure 20. The first thing to note is that placing a capacitor across the terminals of the earphone can produce substantial high frequency response smoothing when the earphone is driven from a high impedance amplifier. If, in addition, the "horn" formed by a stepped-bore earmold construction is added, an additional improvement in response smoothing is obtained, as well as a substantial increase in output above 2 kHz, as shown in Figure 20b. Note also that the stepped-bore earmold has shifted the second response peak at 2200 Hz up to 2700 Hz, the average frequency of the external ear resonance. In order to help compensate for the loss of external ear resonance that accompanies earmold insertion, it is sometimes useful to retain a peak in the earphone coupling system at 2700 Hz while damping all the other peaks, which can be obtained by the proper combination of damping and tubing diameter. For the present purposes, however, note that the application of two damping elements in the earmold tubing produces a smooth response curve even though neither damper is near the tip of the earmold. This two-damper approach is similar to the one described by DiMattia (1958) for use with stethoscope-type headphones.

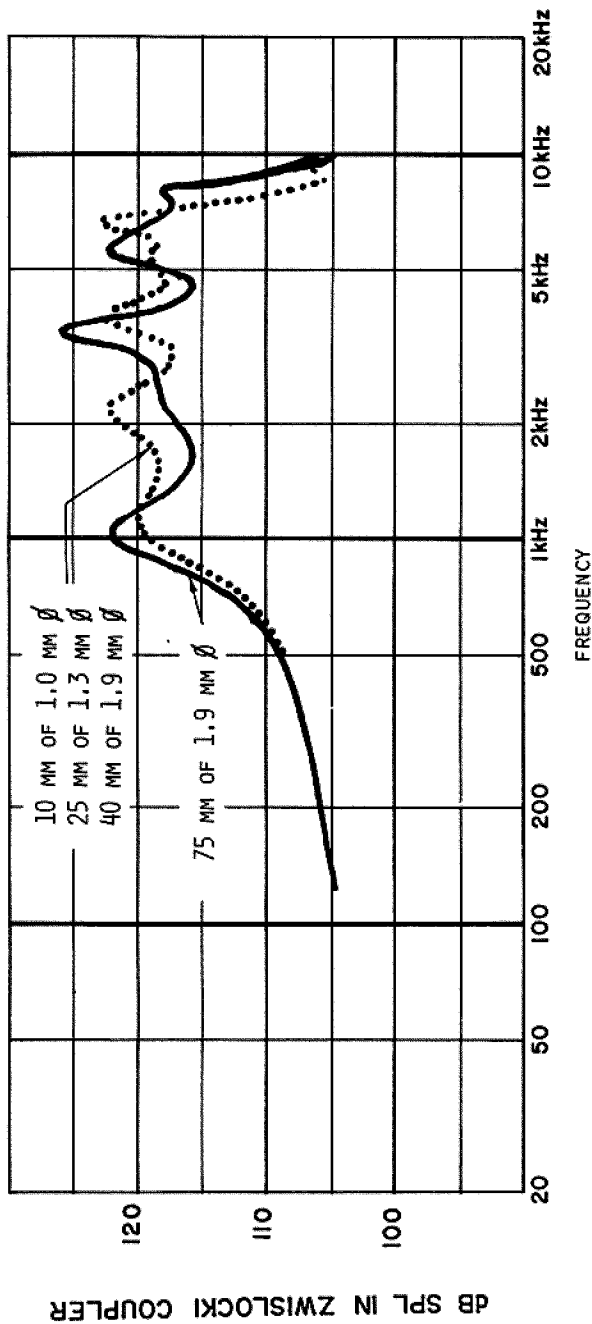

Figure 17. Response smoothing with 1500  $\Omega$  located at BP-1712 earphone outlet and 75 mm of constant diameter coupling (solid line) and stepped diameter coupling (dotted line).

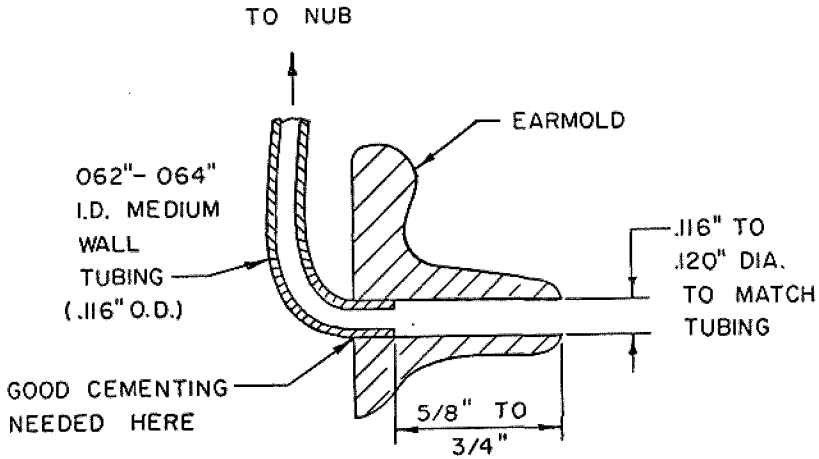

Figure 18. Dual-bore earmold recommended by Radioear for use with a hearing aid that employs a conventional earphone. (Reprinted with permission from Lybarger, 1970.)

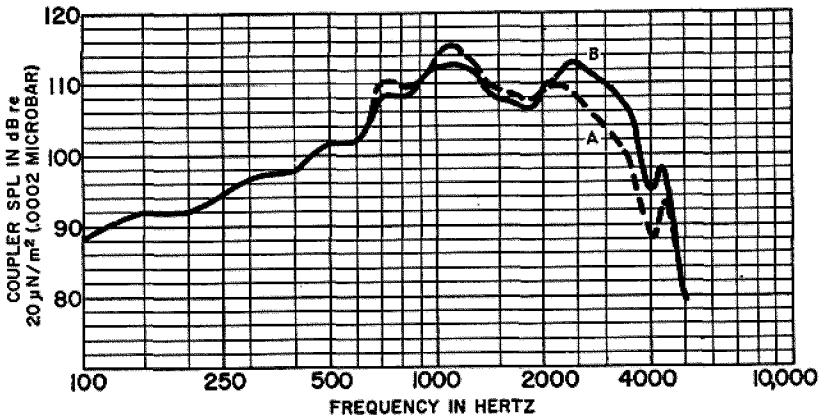

Figure 19. Increased high frequency output obtainable with conventional hearing aid earphone using dual-bore tubing configuration. (Reprinted with permission from S.F. Lybarger, Ear molds, in J. Katz (ed.), *Handbook of Clinical Audiology*, © 1972, The Williams & Wilkins Co., Baltimore.)

This earmold was originally called a 6R10 earmold because until recently the only suitable damping elements available were of the sintered-metal construction (such as the Knowles BF-1540 series). When dampers having better acoustic characteristics became available, a greater high frequency output with better overall response smoothness became possible, which resulted in the change of the earmold name from 6R10 to 6R12 (meaning the Zwislocki coupler response at 6 kHz is 12 dB higher than the

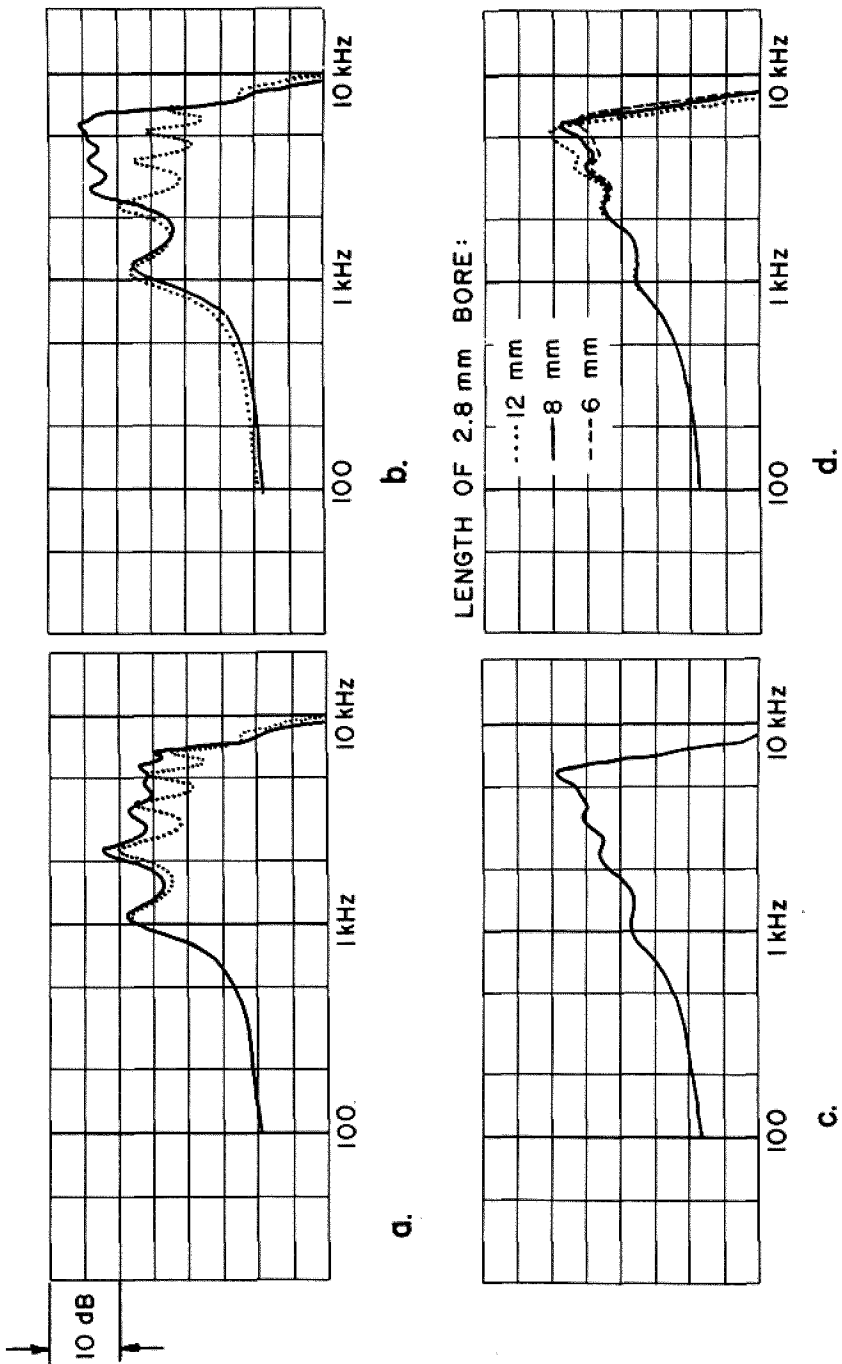

Figure 20. Evolution of 6R10 broadband earmold. a, Shunt capacitor added ( $0.2\mu\text{F}$  across receiver); b, "horn" added; c, damping added; d, final tuning.

1-kHz response). The construction and frequency response of the 6R12 earmold are shown in Figure 21 for the earphone mounting and electrical drive conditions described for Figure 4.

**An Improved Damping Resistance** The improved fused-mesh damping element developed by Carlson and Mostardo (1976) has been made commercially available (Knowles Electronics, BF-1859 series). From a technical standpoint, these damping elements exhibit a nearly pure resistance, so that they introduce only a negligible discontinuity into the transmission line. From a practical standpoint, they allow better smoothing of low frequency tubing resonances with improved high frequency output.

Although these damping elements were primarily designed to fit snugly in 1.9-mm (#13) earmold tubing, they can be used at several other places along the transmission line. Figure 22, for example, illustrates the fact that frequency responses very similar to the 6R12 frequency response can be obtained with a *single* (very carefully placed) damping element located in the earmold tubing, or with two damping elements located inside the hearing aid. In the latter case, the earmold itself retains only the stepped-bore construction and is called an “undamped 6R12.”

### Exponential Couplers (Horns)

The theory of acoustic horns is well known. The impedance transformation that can be obtained by the use of a horn is equal to the ratio of the outlet area to inlet area. The pressure transformation is therefore equal to the square root of the outlet-to-inlet area ratio, or directly equal to the output-to-inlet *diameter* ratio. This transformation obtains above some minimum cutoff frequency, which for exponential horns is commonly called the flare cutoff frequency,  $f_c = mc/4\pi$ , where  $c$  is the velocity of sound and  $m$  is the flare constant determining the increase in area  $A$ , with distance  $x$  along the horn in accordance with the equation  $A = A_0 e^{mx}$  (see, for example, Olson, 1957, pp. 112–114).

Figure 23 shows the relationship between tubing cross-sectional area and tubing length for an exponential horn having two different theoretical flare rate cutoff frequencies: 1 kHz and 2 kHz.

Three comments need to be made about the relationship in Figure 23:

1. When an “exponential horn” is used in a closed system it is more properly called an “exponential coupler.”
2. The effective cutoff frequency of an exponential coupler is usually two to three times the theoretical flare cutoff frequency in the configurations of interest in hearing aid design.
3. A “horn” coupler does not have to have a smooth taper in order to achieve effective transfer impedance. In practice, very similar results to

the continuously tapered transmission line can be obtained as long as the distance between the steps is small compared with one-quarter of a wavelength. When the distance between steps is *not* small compared with one-quarter of a wavelength, the impedance discontinuities introduced by the steps can be exploited to produce additional frequency-response control.

It is interesting to see how the steps in a practical stepped-diameter hearing aid coupling system compare with that required of a perfect exponential coupler. One such comparison is included in Figure 23. Keeping in mind that the practical cutoff frequency is likely to be two to three times the calculated flare cutoff frequency, the curves in Figure 23 would indicate that perhaps above 2 to 3 kHz (when mounted in a hearing aid with internal stepped-bore tubing), a high acoustic impedance earphone used with a conventional earmold should exhibit a 6-dB greater high frequency output than if the stepped-diameter coupling system were not used. With the addition of a stepped bore in the earmold, a total of 12 dB greater high frequency output can be expected. In particular, the use of an earmold such as the 6R12 earmold might be expected to produce a net improvement of 6dB in high frequency output compared with a conventional earmold. An approximation of that result obtains in practice, as shown by the curves in Figure 24. These curves show the increase in high frequency response of a broadband hearing aid that can be obtained by progressively boring out the earmold. (It should be noted that the increased high frequency output shown in Figure 24 can only be obtained with an earphone designed to maintain a high acoustic source impedance at high frequency. The results shown here were obtained with a BP-1712 earphone mounted in an OTE hearing aid case, as shown in Figure 16.)

### A Delivery Problem

There is a practical obstacle to the design of hearing aids using more sophisticated earmold acoustics: the delivery problem. Many hearing aid dispensers are still not adequately familiar with the predictable low frequency response control (Lybarger, Chapter 10, this volume) that can be obtained through the proper use of earmold venting. The addition of variations in high frequency response caused by earmold design is not likely to improve the situation.

Assume for the moment that someone designs a hearing aid using a variation of the 6R12 earmold, and produces the smooth high frequency emphasis response shown in Figure 25. (Note that Figure 25 shows the *insertion gain* and not the coupler response of the laboratory hearing aid. The latter exhibits a substantial peak at 2700 Hz.) If this hearing aid is

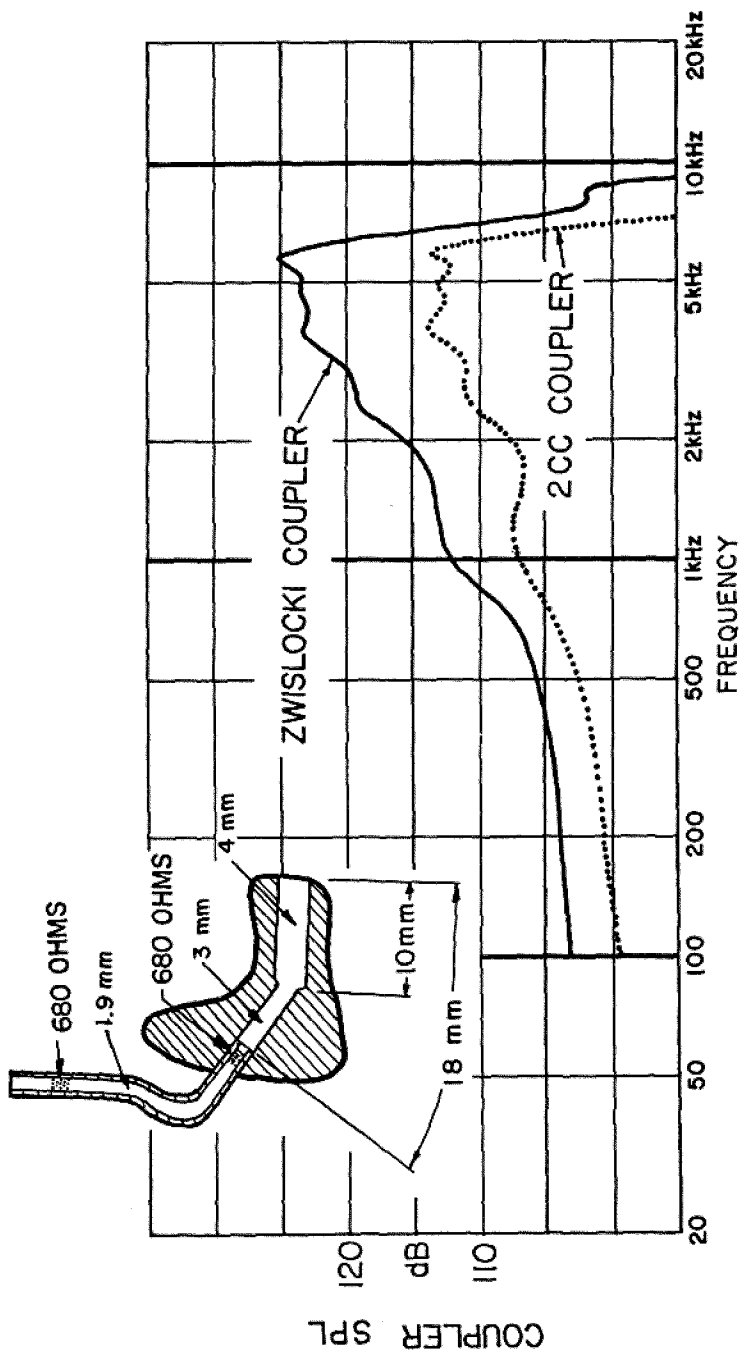

Figure 21. Response of broadband earphone with 6R12 earmold. (Reprinted with permission from Knowles and Killion, 1978.)

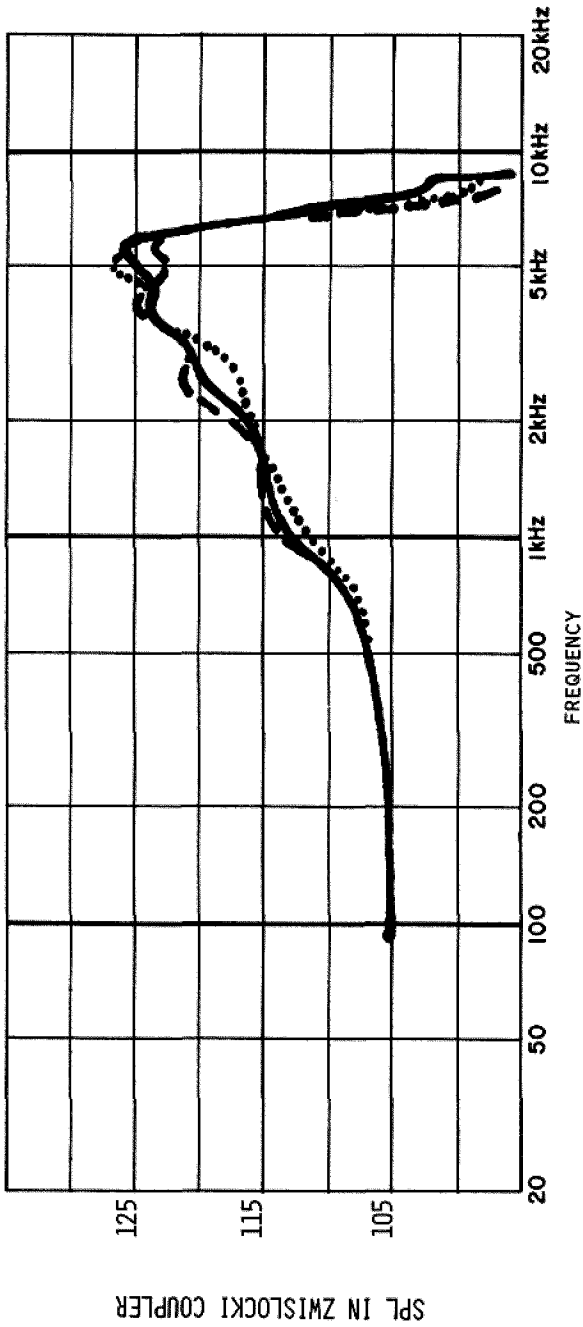

Figure 22. Response of broadband earphone with alternate damping of 6R12 earmold: standard 6R12 earmold (two 680- $\Omega$  dampers in earmold tubing) (solid line), in-the-aid damping (1500  $\Omega$  at earphone outlet and 680  $\Omega$  at earhook tip) (broken line), and single-element damping (single 1500  $\Omega$  in earmold tubing) (dotted line).





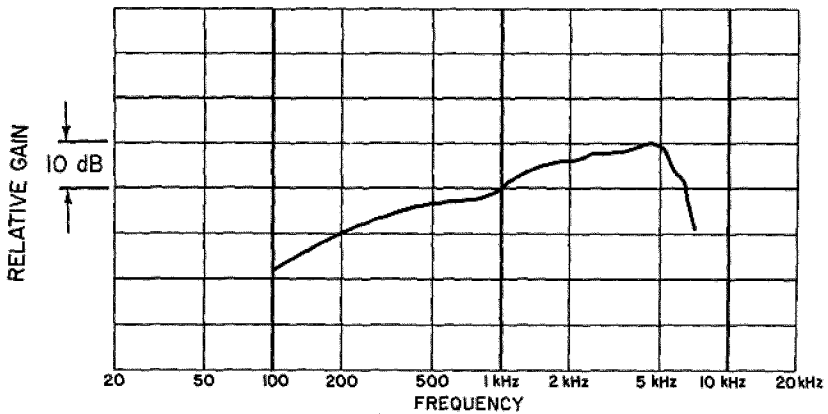

Figure 25. Insertion gain vs. frequency for laboratory hearing aid. (Reprinted with permission from Knowles and Killion, 1978.)

delivered along with a conventional earmold, the response change shown in Figure 26 is obtained. Worse yet, if it is evaluated in the clinic using a "stock" earmold (as is often done, unfortunately), the response change shown in Figure 27 may be obtained. Instead of a hearing aid with a 6-kHz bandwidth, the hearing aid now has an apparent bandwidth of only 2 to 3 kHz.

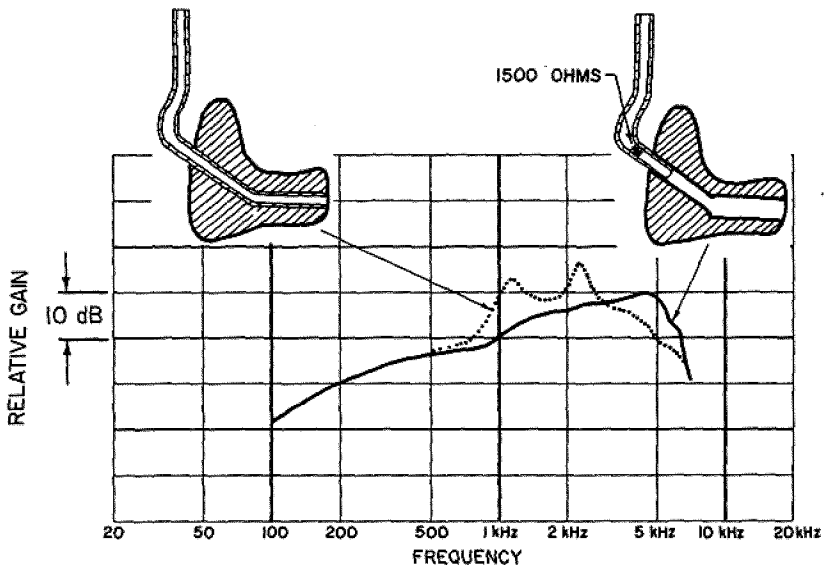

Figure 26. Insertion gain of laboratory hearing aid with recommended earmold (solid line) and conventional earmold (dotted line). (Reprinted with permission from Knowles and Killion, 1978.)

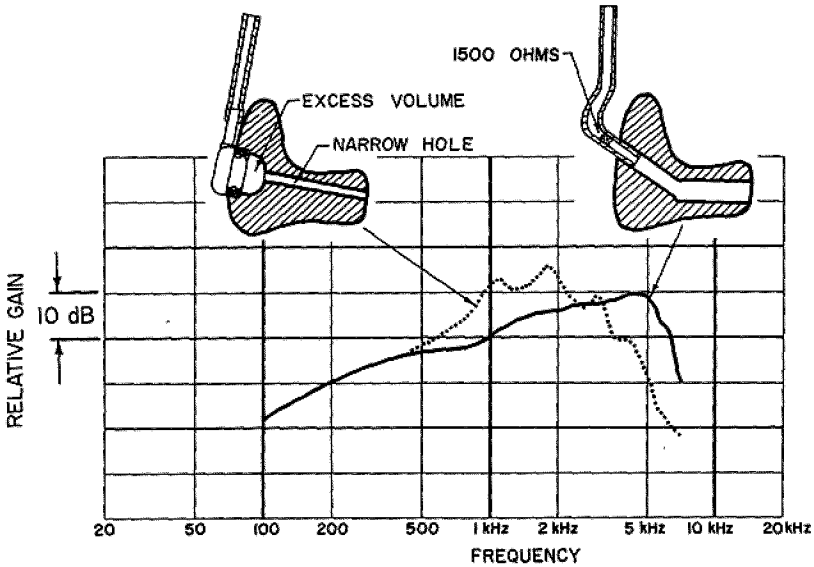

Figure 27. Insertion gain of laboratory hearing aid with recommended earmold (solid line) and improper snap-in earmold (dotted line). (Reprinted with permission from Knowles and Killion, 1978.)

There may be times when exactly the response change shown in Figure 27 is desired. The increased response in the 1- to 2-kHz region caused by the presence of the cavity in the transmission line might mean that a hearing aid with substantially lower battery drain could be used with some clients. Such an earmold design has been suggested recently by Goldberg (1977, 1978), as shown in Figure 28. This earmold is commercially available through at least one earmold laboratory.

### Another Look at the Battery Drain Trade-Off

It is of some interest to look at the reduction in battery drain (class A amplifier) that can be obtained by the use of stepped-bore earmold construction. Figure 29 shows the same family of maximum undistorted output curves shown in Figure 1, except that a 6R12 earmold has been substituted for the well-damped conventional earmold. An undistorted output exceeding 105 dB can be obtained over the entire frequency range from 200 to 6000 Hz, with a battery drain of only 0.35 mA. This compared favorably with the 1 mA that was required with the well-damped conventional earmold. The earmold damping for Figure 1 probably exceeds the level that would be used in a commercial hearing aid, so the comparison may be slightly exaggerated, but the point is not. The use of a stepped-bore earmold may make it practical to employ sufficient damping in the response curve to

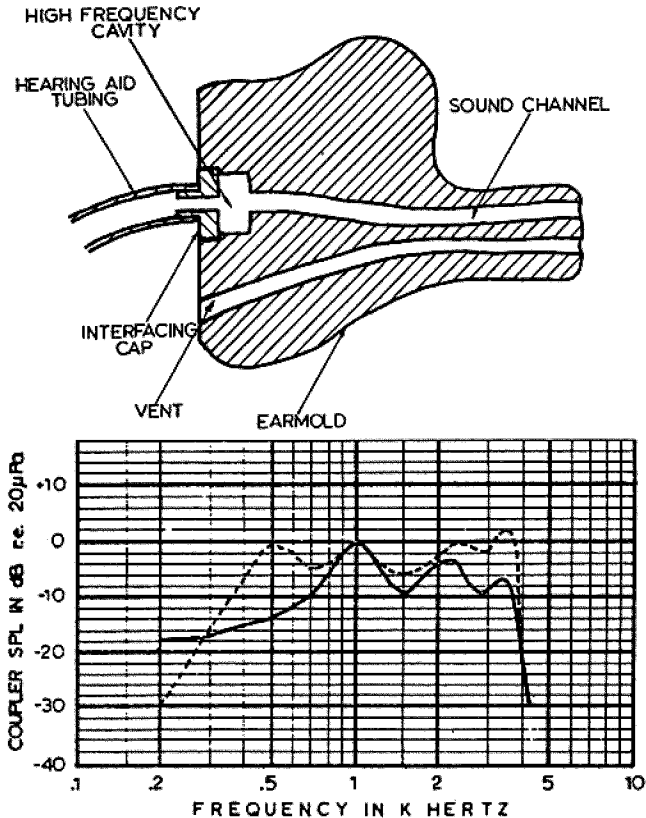

Figure 28. Example of earmold using lumped elements in transmission line (dotted line) compared with conventional (solid line) earmold. (Reprinted with permission from Goldberg, 1977.)

produce a truly smooth frequency response, without incurring the increased battery drain penalty discussed earlier.

### Amplifier Source Impedance

A final response control measure available to the hearing aid designer should be mentioned. Figure 30 shows the change in earphone frequency response caused by changes in the source impedance, i.e., changes in the output impedance of the hearing aid amplifier.

The three curves in Figure 30 have been normalized to the same output level at 100 Hz to illustrate the change in frequency-response curve shape. The *maximum* undistorted output levels obtainable with a single-ended class A amplifier stage and 1.5 V-supply are independent of the amplifier

SUPPLY: 1.5V  
 AMPLIFIER: CLASS A, SINGLE ENDED  
 BIAS CURRENT: NOMINAL RATED BIAS FOR EACH EARPHONE IMPEDANCE  
 EARMOLD: 6R12

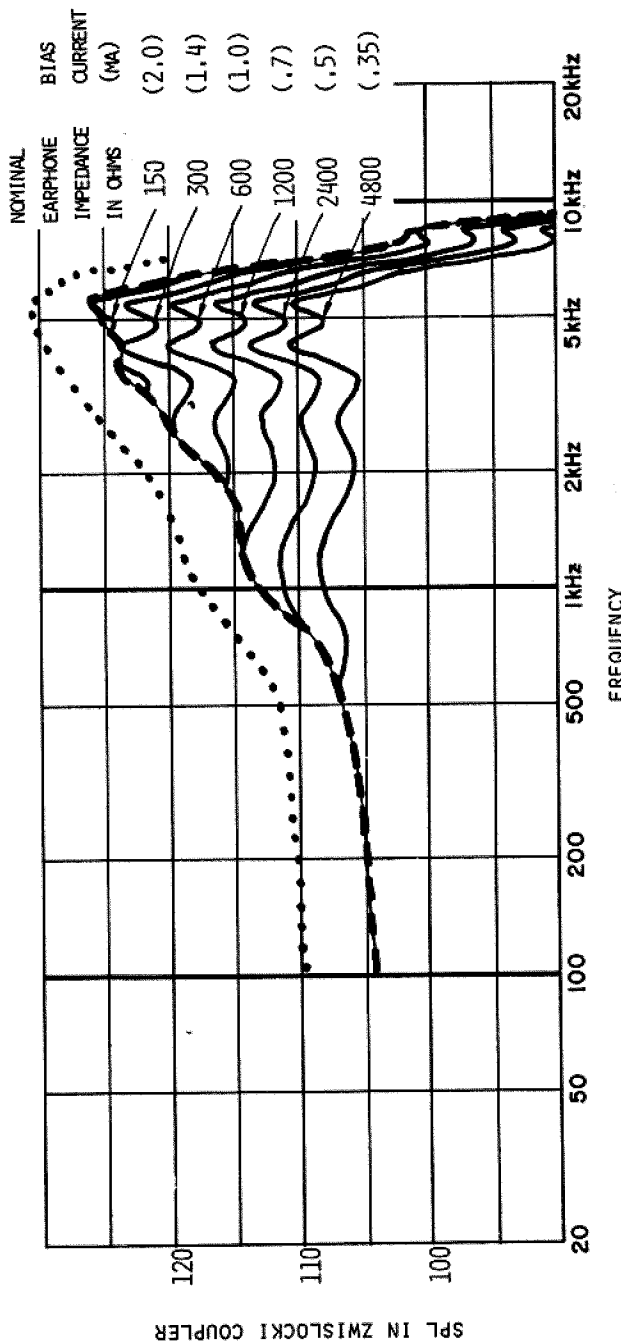

Figure 29. Maximum undistorted output of BF-series earphone with well-damped stepped-bore earmold, limited by earphone overload (dotted line), amplifier current clipping (broken line), and amplifier voltage clipping (solid line).

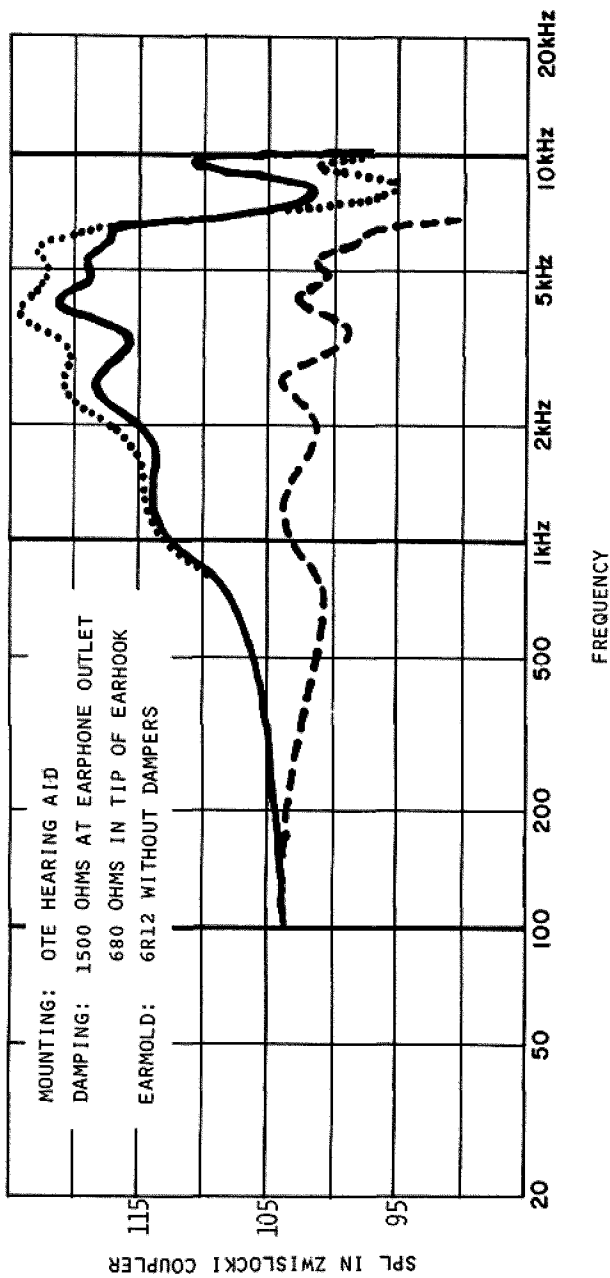

Figure 30. Effect of source impedance on frequency response of BP-series earphone. Response obtained with electrical source of high impedance (constant current) (solid line), high impedance with shunt capacitor (dotted line), and low impedance (constant voltage) (broken line).

output impedance, which is generally determined by the electrical feedback conditions. Thus the *maximum* undistorted high frequency output will be the same for both high impedance and low impedance class A amplifiers (see Figure 29), but the low level frequency response curve will be substantially different (as illustrated in Figure 30).

### SUMMARY AND CONCLUSIONS

There are surprisingly few technical limitations to hearing aid performance. Except in those cases where extremely high gains or sound pressure levels are required, the present state of the electronic and transducer art permits almost any conceivable combination of electroacoustic characteristics in head-worn hearing aids, up to and including high fidelity hearing aids. The problem of response peaks introduced by the coupling between the earphone and the earmold tip can be solved in many ways, some of them quite old. (Incidentally, the same conclusion holds for the coupling problem with in-the-ear (ITE) hearing aids, although they were not considered in this chapter.)

Unfortunately, the main problems remain unsolved; we know embarrassingly little about what is required to optimize the electroacoustic characteristics of a hearing aid for a given individual as he goes about his daily life. Indeed, only recently has a consensus appeared in the research literature on the relatively simple question of what electroacoustic characteristics can be used to optimize speech discrimination in a laboratory setting where the task is to repeat fixed presentation level words or syllables. Because hearing aid designers can now produce almost any conceivable combination of characteristics in a hearing aid, they are in an even bigger quandary than before: Which combination of characteristics will provide increased utility for enough hearing aid users to make it economically feasible to produce and properly deliver the improvement to the end user? Providing answers to this question is the challenge facing us. Once it is answered, providing the required hearing aid characteristics will be relatively simple.

# APPENDIX: A LISTENING TEST DEMONSTRATION

## PROCEDURE

In order to illustrate some of the points made in the formal presentation, a listening test demonstration preceded the presentation itself. Five sound reproduction systems were represented (three of them hearing aids), reproducing first a recording of the Oscar Peterson Trio and then of the New York Philharmonic. The standard of reference for all comparisons was a pair of AR3a loudspeakers spaced along one wall of a 170-m<sup>3</sup> (6000 cubic feet) room at the Auditory Research Laboratories at Northwestern University. The sound absorption treatment on the walls of that room was adjusted to provide the 0.3- to 0.5-sec reverberation time typically recommended for recording studios of that volume.

The demonstration used recorded A-B-A comparisons obtained from the output of eardrum-position microphones in a KEMAR manikin after electrical equalization to remove the spectral peak of approximately 15 dB at 2800 Hz produced by the external-ear resonances (a description of the "bridged T" equalization filter is given in Killion, 1979a). In the case of the hearing aid comparisons, the signal obtained with KEMAR "listening" directly to the AR3a loudspeakers (A) was compared with the signal obtained with KEMAR "listening" through the hearing aids (B) to the same loudspeakers. In the other comparisons, the sound reproduction system under test was simply substituted for the reference loudspeakers during the comparison portion.

The audience participants were provided with rating sheets and IBM cards to fill out. They were asked to rate the *similarity* between the sounds heard in segment A and segment B on a 0% to 100% fidelity scale. They were told that if the comparison sound reproduction system did a perfect job of duplicating the sound of the reference sound system, there would be no audible difference between the two segments and a 100% fidelity rating would be expected. A low fidelity rating would be expected if a large difference in sound quality between the reference and comparison systems was heard.

## THE SYSTEMS COMPARED

Figure 31 shows the  $\frac{1}{3}$ -octave band frequency response of the five sound reproduction systems used in the prerecorded listening test comparisons.



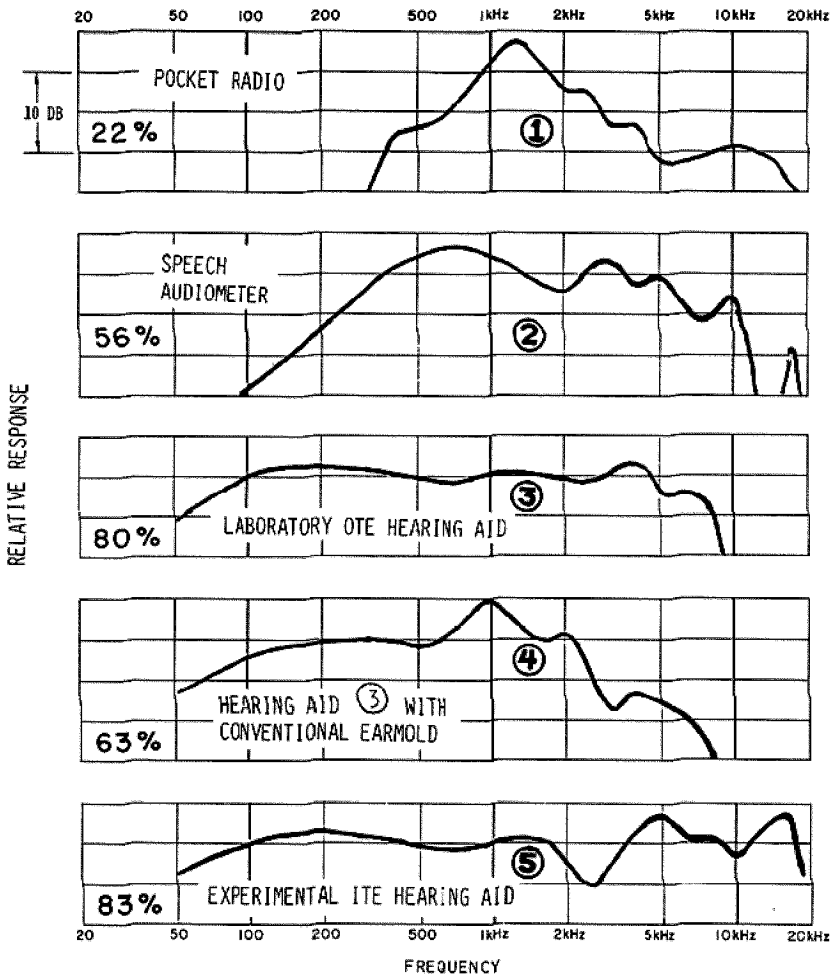

Figure 31. Frequency response of five sound reproduction systems, as measured with  $\frac{1}{2}$ -octave bands of noise and an equalized KEMAR manikin.

System 1 was an inexpensive (\$4.95) pocket radio included as a low fidelity reference.

System 2 represented a high quality speech audiometer assembled from a professional Ampex tape recorder, a Marantz Model 250 high fidelity stereo amplifier, and a pair of TDH-39 earphones—selected to have a typical frequency response—mounted in the standard MX-41 ear cushions. The earphones were carefully taped on a KEMAR manikin to produce a low frequency roll-off (caused by the leak around the ear cushions) equal

to the average obtained from probe-tube measurements on real ears as given by Shaw (1966). Between 200 and 10,000 Hz, the resulting "eardrum pressure" response measured on the KEMAR manikin fell to within 2–4 dB of the predicted average real-ear response calculated from Shaw's data.

System 3 was an experimental OTE hearing aid with an 8-kHz bandwidth. It has less than 1.0-mA battery drain, yet it reproduces a fortissimo passage from a full symphony orchestra at concert hall levels without audible distortion. The 8CR earmold used with this aid is shown in Figure 9.

System 4 was included to provide preliminary information on the effect of earmold variations on the fidelity ratings. System 4 used the same 8-kHz OTE hearing aid that was used for System 3, except that a conventional (undamped) earmold was substituted for the 8CR earmold. A frequency-response comparison between these two earmolds is shown in Figure 9.

System 5 was an experimental ITE hearing aid with 16-kHz bandwidth. Like System 3, it reproduces a fortissimo passage at original levels without audible distortion, but requires a battery drain of 5 mA to accomplish it. With the limited capacity of the small cells typically used in ITE hearing aids, such a high drain corresponds to only a few hours of battery life. System 5 was not constructed as an example of a practical hearing aid, but simply as a demonstration that a hearing aid earphone was capable of delivering that combination of bandwidth and output level. (From a more practical standpoint, at least one individual appears to be benefiting from an upward-shifting frequency transposing body-worn hearing aid whose output is fed to the same type of broadband hearing aid earphone used for these demonstrations. The user in question has an unusual hearing loss configuration: a profound loss at the standard audiometric frequencies but near-normal hearing above 10 kHz (Halperin et al., 1977). In that application, a few extra milliwatts of battery drain was considered a small price to pay for usable output in the 12- to 18-kHz region.) Since the time this paper was presented, a new hearing aid earphone type (Knowles ED series) has been released. That earphone appears to make an ITE hearing aid with 16-kHz bandwidth more practical.

## RESULTS

The system presentation order for the first set of comparisons (Oscar Peterson Trio) was 1,2,3,4,5. The system order for the second set of comparisons (New York Philharmonic) was 1,5,4,3,2. System 2 (the speech audiometer) for example, was heard in the 2nd and the 10th comparison.

The results of the audience ratings are shown in Table 1. The mean percentage of the two ratings for each system is shown in Figure 31. Because of the large sample size ( $N = 122$ ), the standard error of the individual

Table 1. Results of listening test demonstrations conducted during conference presentation

Sound system	Fidelity average ratings		Overall average ratings
	Piano trio <sup>a</sup>	Orchestra <sup>b</sup>	
1—Pocket radio	25%	19%	22%
2—Speech audiometer	51%	62%	56%
3—Experimental OTE hearing aid	71%	89%	80%
4—Experimental OTE aid with undamped earmold	61%	66%	63%
5—Experimental ITE hearing aid	80%	85%	83%

<sup>a</sup>Oscar Peterson Trio, sixth chorus of "The Smudge" (cheerful blues).

<sup>b</sup>New York Philharmonic, fortissimo passage from Beethoven's Violin Concerto in D.

means was small, ranging between 1.3% and 1.9%. Thus most of the differences between the hearing aids and the other sound systems exceeded  $5\sigma$ . These results were subsequently corroborated in more formal listening test comparisons involving additional sound reproduction systems and more comparisons. A description of the more formal tests has been published elsewhere (Killion, 1979b), but the conclusion can be stated here: It is clearly possible to build practical hearing aids whose sound quality will be rated comparably with that of good high fidelity sound reproduction systems.

## ACKNOWLEDGMENTS

The longstanding intense interest of H.S. Knowles in "the hearing aid problem" has been directly responsible for most of the developments reported in this chapter. Many of the recent technical breakthroughs have been direct or indirect results of the ingenuity and teaching of E.V. Carlson. Too many others to mention have contributed solutions, direct experimental data, and/or insights.

The listening test comparisons were recorded at the Auditory Research Laboratories of Northwestern University, Evanston, Ill. The audience rating cards were computer processed by Harvey Stromberg of the City University of New York.

## REFERENCES

- Carlson, E. V. 1974. Smoothing the hearing aid frequency response. *J. Audio Eng. Soc.* 22:426-429.
- Carlson, E. V. 1977. Transducer Coupling System. U.S. Patent #4,006,321.
- Carlson, E. V., and A. F. Mostardo. 1976. Damping Element. U.S. Patent #3,930,560.
- Carlson, E. V., A. F. Mostardo, and A. V. Diblick. 1976. Transducer with Improved Armature and Yoke Construction. U.S. Patent #3,935,398.

- Clack, T. D., J. Erdreich, and R. W. Knighton. 1972. Aural harmonics: The monaural phase effects. *J. Acoust. Soc. Am.* 52:536-541.
- deBoer, E., and J. Bouwmeester. 1975. Clinical psychophysics. *Audiology* 14: 274-299.
- DiMattia, A. L. 1958. Headphone Device. U.S. Patent #2,849,533.
- Goldberg, H. 1977. Earmold Technology Application Notes. *Audiol. Hear. Educ.* 3:11-14.
- Goldberg, H. 1978. An extended range universal earmold. *Hear. Aid J.*, March: 10.
- Halperin, H. R., J. K. Cullen, C. I. Berlin, and M. C. Killion. 1977. Translating hearing aid for 'deaf' patients with nearly normal ultra-audiometric hearing. *J. Acoust. Soc. Am.* 62:S76(A).
- Harrison, H. C. 1929. Acoustic Device. U. S. Patent #1,730,425.
- Heaviside, O. 1899. Cases of vanishing or constancy of the reflection coefficients. In *Electromagnetic Theory*, Vol. II, p. 80. Dover Publications, New York. (Reprinted in 1950.)
- Ingelstam, R., B. Johansson, A. Pettersson, and H. Sjögren. 1971. Non-linear distortion in hearing aids. *Scand. Audiol. (suppl. 1)*: 126-134.
- Killion, M.C. 1976a. Noise of ears and microphones. *J. Acoust. Soc. Am.* 59: 424-433.
- Killion, M.C. 1976b. Earmold plumbing for wideband hearing aids. *J. Acoust. Soc. Am.* 59:S62(A). (Available from Knowles Electronics, Franklin Park, Ill.)
- Killion, M.C. 1979a. Equalization filter for eardrum-pressure recording using a KEMAR manikin. *J. Audio Eng. Soc.* 27:13-16.
- Killion, M.C. 1979b. Design and evaluation of high-fidelity hearing aids. Doctoral dissertation, Northwestern University, Evanston, Ill. (Available from University Microfilms, Ann Arbor, Mich.)
- Killion, M. C., and E. V. Carlson. 1970. A wideband miniature microphone. *J. Audio Eng. Soc.* 18:631-635.
- Killion, M. C., and E. V. Carlson. 1973. A new generation of hearing aid transducers. *J. Acoust. Soc. Am.* 55:393(A).
- Killion, M. C., and E. V. Carlson. 1974. A subminiature electret-condenser microphone of new design. *J. Audio Eng. Soc.* 22:237-243.
- Killion, M. C., E. V. Carlson, and M. D. Burkhard. 1970. Audio Frequency Amplification Circuit. U.S. Patent #3,512,100.
- Knowles, H.S. 1955. Application Notes on "AR" Series Receiver. *Knowles Electronics Engineering Bulletin* #ER-101.
- Knowles, H.S., and M.C. Killion. 1978. Frequency characteristics of recent broadband receivers. *J. Audiol. Tech.* 17:86-99, 136-140.
- Lybarger, S.F. 1949. Damping elements for M-55 receivers. *Radioear Voice*, Jan.-Feb.:T1-T4.
- Lybarger, S.F. 1966. A discussion of hearing aid trends. *Int. Audiol.* 5:376-383.
- Lybarger, S.F. 1970. Advance Dealer Information: Radioear Model 1010 Eyeglass Hearing Aid. Radioear, Cannonsburg, Pa.
- Lybarger, S.F. 1972. Ear molds. In J. Katz (ed.), *Handbook of Clinical Audiology*, pp. 602-603. The Williams & Wilkins Co., Baltimore.
- Mason, W.P. 1927. A study of the regular combination of acoustic elements, with applications to recurrent acoustic filters, tapered acoustic filters, and horns. *Bell Syst. Tech. J.* 6:258-294.
- Mason, W.P. 1930. The approximate networks of acoustic filters. *J. Acoust. Soc. Am.* 1:263-272.

- Moir, J. 1958. *High Quality Sound Reproduction*, pp. 50, 225. Macmillan Publishing Co., New York.
- Mott, E.E. 1944. Indicial response of telephone receivers. *Bell Syst. Tech. J.* 23: 135-150.
- Norton, E.L. 1928. Wave Filter. U.S. Patent #1,681,554.
- Olney, B., F. H. Slaymaker, and W.F. Meeker. 1945. The dipole microphone. *J. Acoust. Soc. Am.* 16:172-177.
- Olson, H.F. 1957. *Acoustical Engineering*. Van Nostrand Reinhold Co., New York.
- Shaw, E.A.G. 1966. Earcanal pressure generated by circumaural and supra-aural earphones. *J. Acoust. Soc. Am.* 39:471-479.
- Stewart, G.W. 1928. Acoustic Wave Filter. U.S. Patent #1,692,317.
- Trimmer, J.D., and F.A. Firestone. 1937. Investigation of subjective tones by means of the steady tone phase effects. *J. Acoust. Soc. Am.* 9:24-29.
- Wegel, R.L., and C.E. Lane. 1924. The auditory masking of one pure tone by another and its probable relation to the dynamics of the inner ear. *Phys. Rev.* 23:266-285.
- Zuercher, J.C. 1977. The calculation of isothermal and viscous effects in acoustic tubes. *J. Acoust. Soc. Am.* 62:S56(A).
- Zwicker, E. 1976. Psychoacoustic equivalent of period histograms. *J. Acoust. Soc. Am.* 59:166-175.
- Zwislocki, J.J. 1971. Special Report: An Ear-like Coupler for Ear-phone Calibration. Laboratory of Sensory Communication, Syracuse University, Syracuse, N.Y.