

A Low-Noise Two-Wire Condenser Microphone Preamplifier

MEAD C. KILLION

Industrial Research Products, Inc., Elk Grove Village, Illinois

Vacuum tube preamplifiers for use with DC-biased condenser microphones have two drawbacks: they require multiwire cables and they are usually noisy. Using the high voltage transistors available today, a two-wire cathode follower type of preamplifier is practical. If a low leakage FET is used at the input, bias resistors of 1000 megohm or more become practical, substantially reducing the input noise level. The design of such a preamplifier, with its associated power supply, is discussed.

INTRODUCTION The DC-biased condenser microphone has become the standard laboratory tool for sound pressure measurements. For this purpose, it has many advantages—including an extremely smooth frequency response—but certainly operating convenience has *not* been one of them.

The low output capacitance (typically 50 pf) of these microphones requires a preamplifier located next to the microphone head; 3 in. of regular microphone cable would cause a 1 dB loss in sensitivity. The traditional solution has been to mount a small vacuum-tube cathode follower in the microphone housing. This necessitates a multiwire shielded cable between the microphone and its power supply. Not only are such cables bulky, but they never seem to be the right length. If the microphone has to be used in more than one location, one usually ends up with 5 lb of cable coiled neatly on the floor somewhere.

While eliminating the bulky cable was the original motivation for a transistorized preamplifier, it soon became obvious that one could eliminate two other irritating features common to most vacuum tube preamplifiers. One of these was the 1 dB or so correction factor that had to be added to the output voltage to compensate for the loss in the preamplifier. This loss has been reduced to about .05 dB in the present design, a correction that can be ignored for all practical purposes. A bonus of such a low-loss design is that it is no longer necessary to calibrate both the microphone head and the preamplifier; all one needs to know is the open circuit calibration of the head itself. It is a real convenience to be able to screw a microphone onto any preamplifier, without worrying about *which* preamplifier.

The last improvement was the reduction of circuit noise. Above about 1 Kc, the noise level of the present preamplifier is below the inherent self-noise of the microphone head; while at low frequencies, the noise level is

within a few dB of the theoretical noise due to the bias resistor.

BASIC CIRCUIT OF A TWO-WIRE PREAMPLIFIER

Two-wire vacuum tube preamplifiers would almost certainly be in extensive use today were it not for the difficulties introduced by the filament, since all that would be required would be to ground the plate and move the cathode load resistor back to the power supply (see Fig. 1a).

The simplest semiconductor version would be to replace the vacuum tube in Fig. 1a with a Field Effect Transistor (FET) as shown in Fig. 1b.

Although its simplicity recommends the circuit of Fig. 1b—it uses only one FET and a couple of resistors—a good 300 V FET is hard to find. Several manufacturers, on the other hand, sell relatively inexpensive bipolar transistors with breakdown ratings of several hundred volts. Adding an NPN transistor to the basic circuit allows the supply voltage for the FET to be bootstrapped back from the output,¹ reducing the voltage across the FET to 5 to 10 V.

CIRCUIT DESCRIPTION OF THE FINAL DESIGN

The schematic of the final preamplifier module is shown in Fig. 2. As can be seen, the FET source (cathode) drives the base of the NPN transistor, which acts as an emitter follower. Resistor R_1 is needed to establish the operating current of approximately .1 ma in Q_1 , since Q_2 requires only about 10 μ amp of base current. Resistor R_2 is added for temperature stability, while R_3 and R_4 form a voltage divider for the FET. Accommodating the wide range of pinch-off voltages specified for a given FET type number is accomplished by selecting R_x at assembly to produce a total preamplifier current drain of about 1.1 ma with 200 V applied. Except for

* Presented October 10, 1966 at the 31st Convention of the Audio Engineering Society, New York.

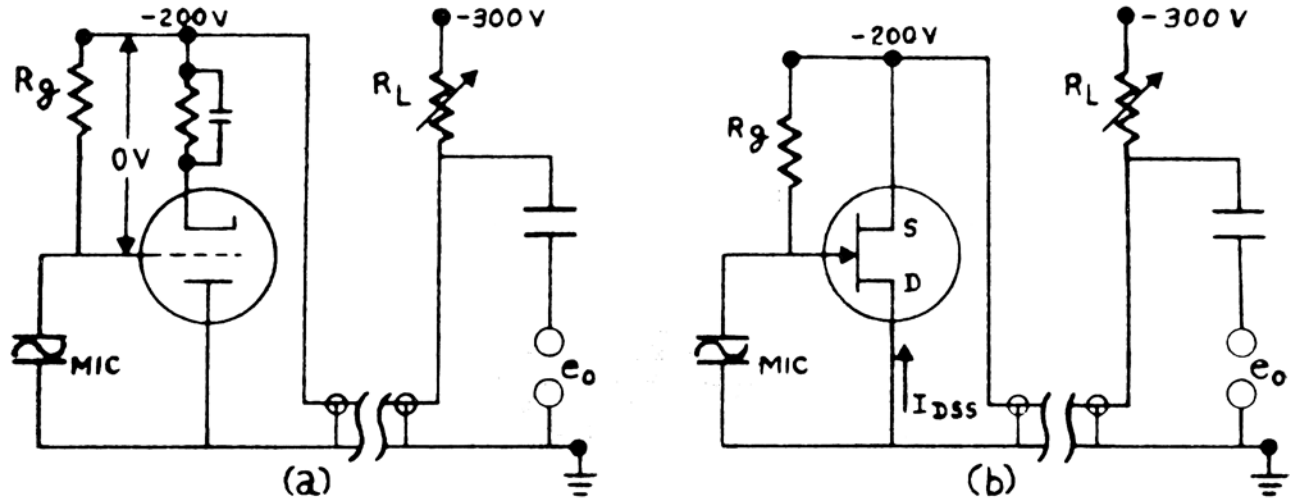

Fig. 1. Pre-amplifier circuits. a. "Two-wire" vacuum tube pre-amplifier. b. Simple FET version.

R_g , metal film resistors are used to avoid excess noise.

It should perhaps be noted that the output phase is shifted 180° from that normally encountered, due to the fact that the microphone is biased at -200 V instead of $+200$ V. This was done for two reasons: 1. High-voltage NPN transistors are easier to get than high-voltage PNP ones; and 2. N-channel FETs are usually less noisy than P-channel devices.

The bias resistor, R_g , supplies the -200 V DC bias to the microphone and acts as a grid leak for the FET. The value of 1000 megohm is unusually high, and was chosen for the reasons discussed below.

It has been known for years that a theoretical lower limit on circuit noise is set by the size of the bias resistor: the higher the resistor, the lower the noise in the pass-band.²⁻⁴ This is easily derived on the basis of the Johnson noise theorem applied to a resistor shunted by a 50 pf capacitor. It turns out, incidentally, that for a given value of resistance, the theoretical input noise is independent of circuit configuration.⁵ What counts for noise purposes is the actual value of the bias resistor (or the parallel value of two bias resistors if a separate grid bias resistor is used), and not the effective input impedance of the pre-amplifier.

In the past, surface leakage problems and grid leakage currents have combined to keep bias resistors down in the neighborhood of 50-100 megohm. The surface leak-

age problem can be completely eliminated by a mechanical design which places all surface leakage paths in shunt with R_g , where they cannot upset the bias.⁶ (The one exception is the surface leakage path across the insulator used in the microphone head itself, but this can be easily checked by simply unscrewing the microphone head; if the bias meter does not move, there is no problem.⁷) This leaves the gate leakage current of Q_1 as the only source of error that remains in the assumption that the DC bias voltage on the microphone head is the same as the DC voltage on the output pin of the pre-amplifier. The low-noise FET chosen for Q_1 has a typical leakage current of 5 pA, which produces a voltage drop of 5 mV across the 1000 megohm bias resistor. Even at 55°C , where the gate leakage is about an order of magnitude higher, the error is only 50 mV out of 200 V, or about .025%. Hence, even with an unusually high bias resistor, it is still possible to substantially reduce the uncertainty in the measurement of the DC bias on the microphone.

The sole purpose of the diode D_1 in shunt with R_g is to insure that any electrostatic discharge always flows through a forward-biased junction.⁸ Without this precaution, a person may pick up enough negative static charge during the winter to damage the FET.

The completed circuit is essentially a cathode follower with unusually high g_m : with .1 mA through the FET and .9 mA through the transistor, the effective transconductance amounts to over 10,000 μmhos . This not only gives an output impedance of less than 100 ohm, but it results in very nearly unity gain. With a 50K load resistor (R_L), the output voltage is within .04 dB of the input voltage.

To obtain low loss with a 50 pf source, however, requires an extremely low input capacitance. (One pf would cause the input voltage to be attenuated by about .2 dB.) One of the chief advantages of the cathode-follower type of circuit, of course, is that any capacitance which appears between the input and output terminals is effectively multiplied by the factor $1 - e_0/e_{in}$. In the present design, all input capacitances are returned to the output terminal. This is accomplished by the boot-strap in the case of Q_1 . In the case of wiring capacitance, it is accomplished by the same mechanical design which solves the surface leakage problem. Since

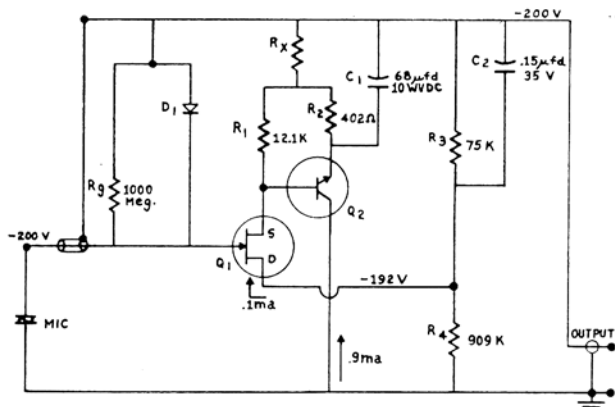

Fig. 2. Circuit diagram of the two-wire pre-amplifier (final design). R_g is a Victoreen RX-15, Q_1 is a 2N3439 and Q_2 is a 2N3685.

the factor $1 - e_o/e_{in}$ is less than 4×10^{-3} in this preamplifier, the effective input capacitance is kept well below 0.1 pf throughout the audio band.

MECHANICAL DESIGN

In assembling the preamplifier module, the resistors and condensers are mounted between two printed-circuit discs $\frac{5}{8}$ in. in diameter, with Q_1 and D_1 on one end and Q_2 on the other. The gate lead of the FET and the hot end of the 1000 megohm bias resistor are not soldered to the circuit board, but are extended out and soldered to the input contact disc. A section of $\frac{5}{8}$ in. I.D. brass tubing is then slipped over the circuit assembly and becomes the outer mold for the epoxy encapsulation of the entire assembly. Figure 3 shows the module before and after encapsulation in its brass shell.

Encapsulation serves to: 1. eliminate any residual vibration sensitivity; 2. improve thermal stability; and most important, 3. eliminate all surface leakage paths except one from input contact disc to brass shell.

Since the brass shell is connected to the -200 V output terminal, the one remaining leakage path is placed in parallel with the bias resistor. Note also that the entire circuitry is surrounded by the brass shell, so that it forms a driven capacitive shield around the input wiring.

The completed preamplifier circuit module is $\frac{3}{4}$ in. in diameter by 1.6 in. long.

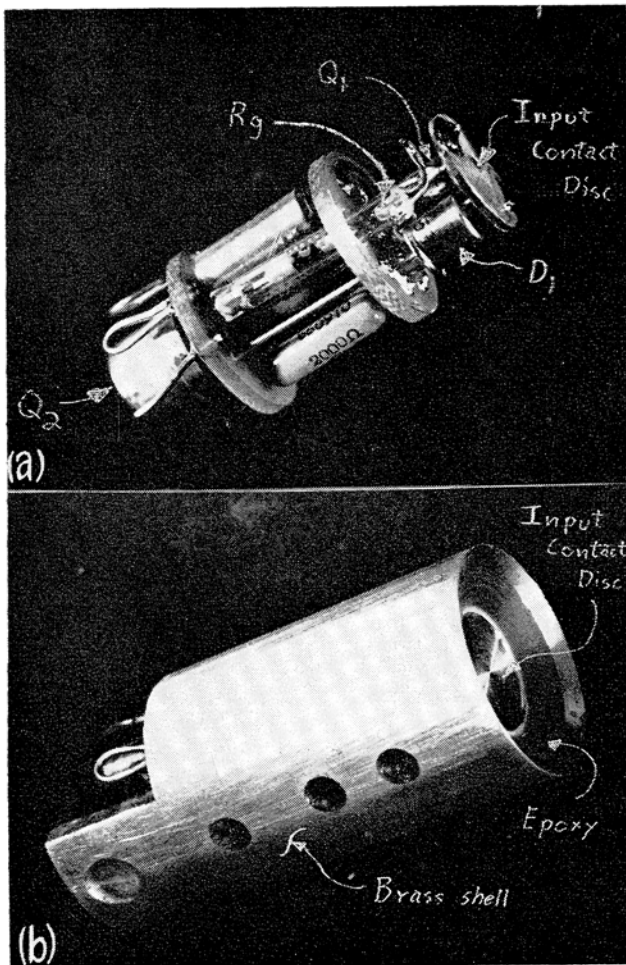

Fig. 3. Preamplifier circuit module. a. Before encapsulation. b. After encapsulation in its brass shell.

HOUSING ASSEMBLY

Figure 4 is a cross-section drawing of the housing assembly with the preamplifier module installed and a microphone head screwed into place.

The dimensions of the guard shield, which extends inside the microphone head, have an effect on the calibration of microphone sensitivity. In the early work on condenser microphones, no guard shield was used, and

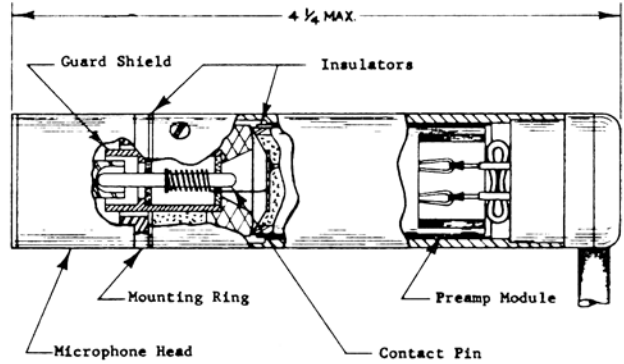

Fig. 4. Completed microphone assembly.

the parasitic capacitance between the microphone shell and the contact pin produced a few tenths dB uncertainty in the series substitution determination of the open-circuit sensitivity of the microphone. Capacitance between the microphone shell and the contact pin attenuates the output in normal use, but increases the apparent output when the head is driven from a voltage source during the series substitution. Adding the guard shield can appreciably reduce, but not completely eliminate, this parasitic capacitance. The solution has been to standardize the dimensions of the guard shield, so that everyone obtains the same (small) error. The standard has just been changed, and the guard shield dimensions in the present design conform to the latest standard.⁹

The guard shield may be either grounded or driven from the output voltage. The former has the disadvantage that the approximately 3 pf between the contact pin and the guard shield attenuates the input voltage to the preamplifier. (This does not cause a calibration error, of course, since it always appears as part of the input capacitance of the preamplifier; it causes the same loss in the series substitution calibration as it does in normal operation.) In the present design, the guard shield is insulated from the housing and is connected to the output voltage simply by butting the brass shell of the preamplifier module against it. Here, again, the DC surface leakage paths across the contact pin insulators are placed in shunt with the bias resistor.

Operating the guard shield at 200 V DC does create one problem: when the microphone is not screwed on, the guard shield is exposed and could produce a mild shock.¹⁰ This is not a safety consideration, since the maximum DC current available is limited to a few milliamps by the series load resistor. The thought of someone being startled and dropping an expensive microphone head, however, was an unpleasant one. Hence, the exposed portion of the guard shield is made of anodized aluminum, with a .001 in. deep insulating "hard coat" which has proven quite durable in other applica-

tions. The back portion of the guard shield, which makes contact with the preamp module, is made of brass to avoid contact problems. The two halves of the guard shield are press-fit together and the junction is sealed with epoxy. This avoids any possible corrosion problems at the brass-aluminum interface.

The standard way of determining the preamplifier loss is to insert a voltage between the (grounded) housing and the microphone mounting ring, which is insulated from the housing (see Fig. 5). In the present design,



Fig. 5. Series substitution (insert) method for determining preamplifier loss.

a set screw shorts the mounting ring to the housing for normal use. To calibrate, the set screw is removed and a 4-terminal contact clamped around head and housing.

POWER SUPPLY

The easiest power supply to use, of course, is a battery. The total drain of the preamplifier and metering circuit is only about 2.7 mA. Hence, a 300 V U200 battery will supply nearly 50 hours of operation, at a cost of about 16¢ per hour.

For most purposes, however, a line-operated power supply is preferable. Obtaining a high-voltage power supply quiet enough to be equivalent to battery operation is somewhat difficult, especially in the $1/f$ or "flicker" region. The design was made substantially easier by using one of the many inexpensive low-drift operational amplifiers currently available. A temperature-compensated 8.4 V Zener, Z_1 , provides a stable reference voltage at one of the differential inputs, and a voltage divider from the output provides the other input (see Fig. 6, the schematic of the complete power supply). The large common-mode input range of the operational amplifier allows both inputs to be at -8.4 V while the output is referred to ground. The output of the operational amplifier drives the base of Q_3 , the series regulating transistor.

The wide-band rms noise of the power supply—measured by placing a Ballantine voltmeter directly across the -300 V terminal—is less than $100 \mu\text{V}$. Because of the low output impedance of the preamplifier, this contributes less than $.3 \mu\text{V}$ to the preamplifier noise level. Metal film resistors had to be used for R_5 and R_6 to make certain that the flicker noise would be unimportant.

To keep the external magnetic flux to a minimum, the electrostatically shielded line transformer is wound to operate at one-half the primary flux normally used, and then encapsulated in a mu-metal case.

METERING CIRCUIT

As mentioned earlier, the DC bias voltage applied to the microphone head is within a few millivolts of the voltage on the output pin of the preamplifier. Since the

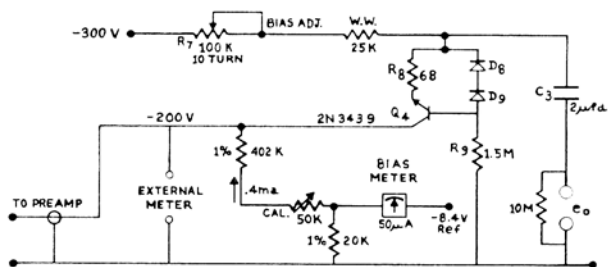
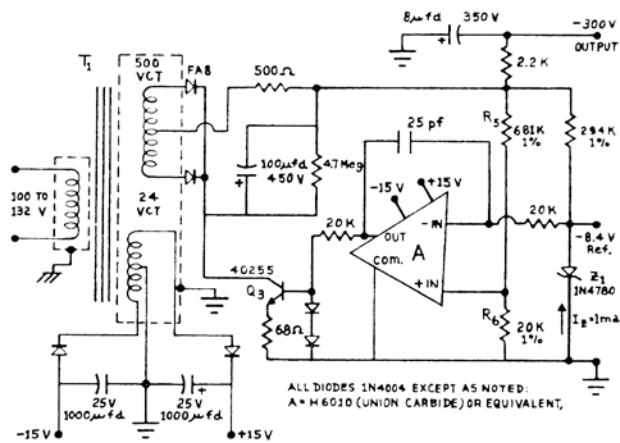

Fig. 6. Line operated power supply.

preamplifier draws a constant current of approximately 1 mA, adjusting the bias is accomplished simply by adjusting R_7 , the load resistor.

An expanded scale voltmeter is included in the power supply to continuously monitor the bias. It was obtained by connecting one side of a $50 \mu\text{amp}$ meter to the reference Zener, and the other side to a voltage divider from the 200 V line. The full-scale range of the meter is from about 188 V to 212 V. Once calibrated, it allows precise setting of the bias voltage to the microphone head. A change of one small division on the bias meter corresponds to a shift of approximately .03 dB in microphone sensitivity. Such a high resolution is useful principally as an "early warning system." Any shift in the operating bias—due, for example, to moisture in the microphone head—is easily noticed and corrected. For routine laboratory use, of course, an accuracy of ± 0.1 dB is more than adequate.

SHORT-CIRCUIT PROTECTION

If the e_0 terminals (Fig. 6) were shorted, and at the same time the preamplifier input pin were accidentally shorted to ground, the 2 mfd decoupling capacitor C_3 would be discharged through the junction of the input FET. The 40 millijoules of energy stored in C_3 would be enough to burn out the FET. The combination of short-circuits mentioned above is not a likely one, especially since they would have to occur in the sequence given. On the other hand, unencapsulating an epoxy-encapsulated preamplifier is a tedious chore. Hence, a current limiting transistor, Q_4 , was added between the decoupling capacitor and the output. The base current supplied by R_9 is enough to keep Q_4 well into saturation under normal operation. Resistor R_8 and diodes D_8 and D_9 form a simple circuit which limits the maximum

current in Q_4 to about 10 mA. Resistor R_8 adds another 68 ohm to the impedance seen at the e_o terminal, but the reactance of the 2 mfd decoupling capacitor does not get down to 68 ohm until 1200 cps anyway.¹¹

EQUIVALENT CIRCUIT OF THE COMPLETED PREAMPLIFIER

Figure 7 is the approximate equivalent circuit of the

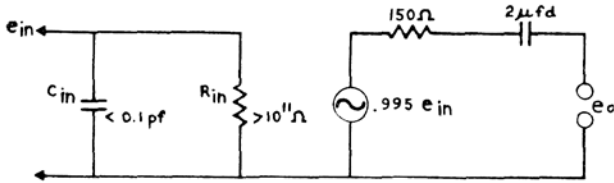

Fig. 7. Equivalent circuit of the completed amplifier when used with the power supply of Fig. 6.

completed preamplifier with its power supply.

The equivalent input capacitance C_{in} includes the effective capacitance between the contact pin and the driven guard shield. The capacitive loading of the open circuit microphone voltage due to C_{in} is less than .02 dB.

FREQUENCY RESPONSE

The equivalent circuit of Fig. 7 cannot be used directly for predicting the preamplifier response outside the audio band, since the effective input impedance depends on the factor $1 - e_o/e_{in}$. Below 10 cps, the ratio e_o/e_{in} begins to drop as the reactance of the 68 mfd bypass, the capacitor in the preamplifier becomes important. At high frequencies cable capacitance can load the output, causing the ratio e_o/e_{in} to drop.

For most purposes, the curves in Fig. 8 are adequate for estimating the effect of microphone capacitance and cable length on the frequency response. Figure 8 shows the voltage measured at the e_o terminal (on the power supply) with 20 ft of 30 pf/ft cable between the preamplifier and the power supply. A 1 megohm input voltmeter was used, except at very low frequencies, where a 1 megohm input DC recorder was used. In each case, 0 dB refers to the oscillator voltage. (It should be noted that with a short enough cable, all the curves are completely flat to well beyond 100 Kc.)

The .2 Hz cutoff frequency of the preamplifier is not necessarily an advantage; it is simply a by-product of the low-noise design. In practice the barometric release in most microphone heads produces a cutoff frequency of a few Hz. The high-frequency response, on the other hand, is useful with 1/4 in. diameter probe microphone heads, such as the B & K Model 4135, whose response extends beyond 100 Kc. The capacitance of such heads is usually less than 10 pf, which makes the low input capacitance of the preamplifier especially useful.

DYNAMIC RANGE AND NOISE

The available output current of the preamplifier is 1 ma peak, so that the upper limit of the dynamic range is determined by the total load impedance. With the power supply and metering circuit of Fig. 6, clipping starts at about 30 V rms (85 V p-p). In addition, the

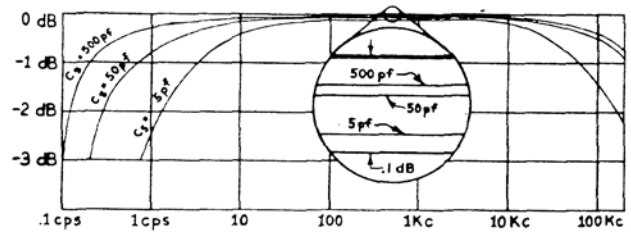

Fig. 8. Frequency response of preamplifier with 600 pf load. The source capacitance, C_s , was mounted in a dummy microphone head in each case.

cable capacitance can cause clipping at high frequencies. With 100 feet of 30 pf/ft microphone cable, for example, this limits the 10 Kc output level to 3 V (or an equivalent sound pressure level of about 134 dB for a WE 640AA head).

The lower limit to the dynamic range is set by the noise level. Figure 9 is a plot of noise density vs frequency for a preamplifier with a 640AA head in place, where the noise density is given by $e_n/\sqrt{[cps]}$. The particular preamplifier module under discussion used a selected FET for Q_1 .¹² Using an unselected FET, the preamplifier noise is typically 3 to 6 dB higher. The dotted curve in Fig. 9 is the inherent self-noise of the 640AA alone, due to its acoustic damping resistance.¹³ The dashed curve is the preamplifier noise with a 50 pf mica condenser across the input.

The output noise of the preamp and a 640AA microphone over the audio band (20 Hz to 20 kHz) is about 5 μ V. With a typical 640AA sensitivity of -50 dB re 1 V/ μ bar, this corresponds to an SPL of 18 dB re .0002 μ bar. Over the speech band (roughly 300 Hz to 4 kHz), the combined microphone and preamplifier noise is about 1.8 μ V, or an equivalent SPL of +9 dB. Latter is only about 3 dB above the noise level of the 640AA in that band.

The difference between the 30 V clipping level and the 5 μ V noise level gives the preamplifier a dynamic range of 136 dB over the audio band.

Figure 10 is the same as Fig. 9, except that the microphone is a 1 in. diameter B & K Model 4132 condenser microphone head. It should be noted that although the noise level of the B & K head is about 5 dB higher, this head is also about 5 dB more sensitive than the 640AA. In addition, the capacitance of the B & K head measured 71 pf below 3 kHz (with 200 V bias). The net result is that the equivalent SPL of the total noise (preamplifier and microphone) is slightly lower with the B & K head.

The right-hand axis in Figs. 9 and 10 measures the

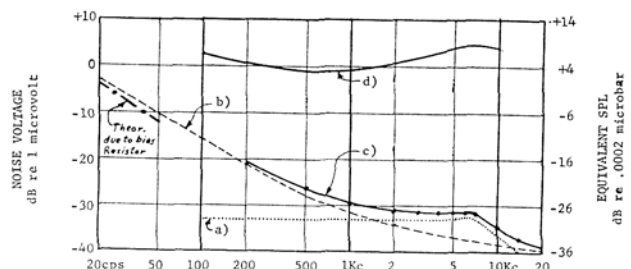

Fig. 9. Noise spectra. a. Self-noise of the 640AA preamplifier with 200 V DC bias applied. b. Preamplifier noise with 50 pf Mica capacitor in dummy head. c. Total measured input noise. d. Total input noise on an octave band basis.

equivalent SPL (*re* .0002 μ bar) of the noise curves for frequencies below about 10 kHz. The *self-noise* of both the 640AA and the B & K 4132 is equivalent to an SPL of about +11 dB *re* .0002 μ bar, over the 20 Hz to 10 kHz band.

The results plotted in Figs. 9 and 10 were obtained with a General Radio wave analyzer after amplification with a low-noise Keithley amplifier. Even so, a small correction for the short-circuit noise contribution of the Keithley was required to obtain the noise density of the preamplifier alone. The technique used to obtain the "total noise" curves in Figs. 9 and 10 was to put the microphone inside an old-fashioned pressure cooker (with 6 clamping bolts to hold the lid) which was itself placed inside the floating anechoic chamber at I.R.P.I. Above about 300 Hz, the noise was unchanged when the pressure cooker lid was removed. (The pressure cooker gave a minimum isolation of 30 dB above 100 Hz.) All noise measurements, incidentally, were made using the line-operated power supply.

Table I is a brief summary of the preamplifier specifications in the audio band, when used with the power supply of Fig. 6.

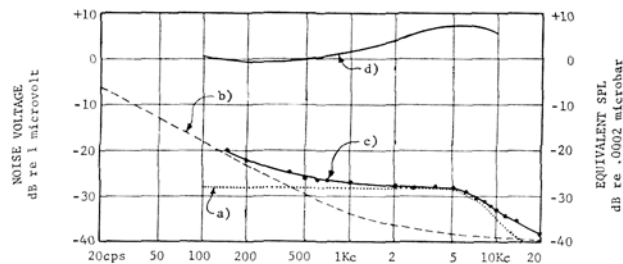

Fig. 10. Noise spectra using a different microphone from Fig. 9. a. Self-noise of B & K 4132 with 200 V DC bias applied. b. Preamplifier noise with 68 pf Mica capacitor in dummy head. c. Total measured input noise. d. Total input noise on an octave band basis.

ACKNOWLEDGMENTS

The author is indebted to E. V. Carlson, who originally suggested a two-wire condenser microphone preamplifier, and whose embarrassing questions brought about many of the improvements.

NOTES

1. Adding the transistor also makes it possible to obtain essentially 0 dB loss in the preamplifier.

2. J. B. Johnson, "Thermal Agitation of Electricity in Conductors," *Physical Review* 32, 102 (1928). See espe-

TABLE I. Preamplifier specifications.

Voltage gain (e_o/e_{in})	$-.04 \pm .02$ dB
Input impedance	$>10^{11}$ ohm shunted by less than .1 pf
Output impedance	150 ohm (typ) in series with 2 mfd
Broad-band noise (50 pf source, 10 Hz to 100 kHz)	5-10 μ V (typ)

cially his Fig. 5, a graph of noise voltage vs shunt resistance for a fixed capacitor.

3. H. G. Baerwald, "The Absolute Noise Level of Microphones," *J. Acoust. Soc. Am.* 12, 131 (1940).

4. P. S. Veneklasen, "Instrumentation for the 640AA Condenser Microphone," *J. Acoust. Soc. Am.* 20, 808 (1948).

5. A. K. Nielsen, "The Calibration of Condenser Microphones," *Acustica* 2, 117 (1952).

6. Such a mechanical design was shown by P. S. Veneklasen (see Note 4).

7. The DC gain of the preamplifier is about .9, so that a 110 mV shift in bias on the microphone (due, for example, to microphone leakage) would cause a shift of 100 mV on the bias meter. With the expanded scale bias meter described later, such a shift would be just discernible.

8. In order to insure that the resistance of D_1 does not appreciably shunt R_o and thereby increase the noise, it must be a low-leakage diode. One way to get such a diode is to use the gate-to-channel junction of another low-leakage FET. Another good candidate is the base-collector junction of a 2N930 transistor.

9. *American Standard for the Calibration of Microphones S1.10-1966* (revises Z24.A-1949 and Z24.11-1954).

10. The few microamperes available at the center contact pin, on the other hand, are well below the threshold of sensation.

11. Adding R_s also causes about .01 dB loss in output voltage as seen in e_o , which was not considered important either.

12. More precisely, Q_1 was the best of three 2N3685 and three 2N3686 FETs purchased "off the shelf." At the moment, little can be gained by obtaining a factory selected FET, because of the NPN transistor noise. This is partly due to the .9 ma collector current in Q_2 , which was dictated by output drive requirements and is higher than would be suggested by noise consideration. As device technology improves, it may well become possible to build a preamplifier whose noise is less than the self-noise of the 640AA everywhere above 100 Hz. This would require a bias resistor of about 30,000 megohm; but from our experience to date, such a condition might be entirely practical.

13. A. G. Becking and A. Rademakers, "Noise in Condenser Microphones," *Acustica* 4, 96 (1954).

THE AUTHOR

Mead C. Killion received his A.B. degree in mathematics from Wabash College in 1961 and is currently working towards his Master's degree at the Illinois Institute of Technology. He has been with Industrial Research Products, Inc., since 1962 where he has been involved in the design of electro-acoustical transducers and instrumentation. A previous paper on a

7-watt "Class D" audio amplifier was presented before the Chicago Acoustical and Audio Group in 1964.

Mr. Killion is a member of the Acoustical Society of America, the Audio Engineering Society, the Institute of Electrical and Electronic Engineers, and the Chicago Acoustical and Audio Group of which he is presently treasurer.